



Product Catalogue



When J&C Joel first started selling black wool serge to the theatrical industry in 1978, little did we realise that, 30 years later, we would be offering a product range of the breadth shown in this catalogue. Nor did we have any idea of the variety of industries we would be supplying, from entertainment in its broadest sense, including television studios, concert halls and opera houses, as well as theatres of all sizes, cruise ships, schools, exhibition halls, retail outlets and shopping centres around the world.

Our recently extended 75,000 sq ft factory incorporates everything needed to fulfil your requirements: a drapery manufacturing department that is unrivalled in its skills base; an installation department that has supplied some of the best known venues in the world; and a sales and customer service department determined to ensure that you, our customer, receive the best possible products and service.

Our ambition is simple: to make the experience of buying from J&C Joel as easy as possible and to welcome you back time and time again. We hope this catalogue helps you in selecting the best J&C Joel product for your next project, whatever it may be.

From the whole J&C Joel team, thank you for your custom.

James Wheelwright
Sales Director

J&C Joel is a member of





Carriage Works, Leeds, UK



*Yong Siew Toh Conservatory of Music,
National University of Singapore*



Alley Arts Centre, Strabane, Ireland

Renowned as one of the world's leading theatrical drape manufacturers, J&C Joel has

developed over 30 years and now provides a huge range of products for the whole entertainment industry. From consumables such as gaffer tape and paint to electric pilewind winches and orchestra lifts, from school halls to iconic venues such as the London Coliseum, we aim to deliver every job with the same courtesy, consideration and attention to detail.

With such a broad range of products and services, it is our staff's knowledge, experience and professionalism that have helped us build our business and our reputation. They are, indeed, our most valuable asset.

Unrivalled in their skills base, our seamstresses are able to provide the most complex of backdrops, shaped drapes and concept curtains – for more detailed information about our custom sewing skills, see pages 4-7. We maintain a constant stock of almost 1,000,000 metres of fabric, giving you a choice of over 150 different fabrics, 550 colours and 50 widths. But if the specific fabric you require is not here, then please ask – if we can't find it, the chances are nobody can.

Our thriving contracts department employs all the skills and expertise necessary to undertake the most complex of installations. From design through project management to installation and commissioning, our experience is unsurpassed, encompassing projects as diverse as tracks for crematoria, outside broadcast, school stage systems, powered flying systems and much more.

From our HQ in Halifax, England, we service the entertainment industry around the globe. From our recently expanded 75,000 sq ft facility, we export our products and our expertise to over 75 countries on a daily basis – you will see pictures of both UK and overseas projects as you look through this catalogue.

We have showcased our most popular items, but there are many more parts and widgets that we have not been able to include – and we are constantly adding to our range. If you cannot find what you are looking for here, then please ask – we will probably have in stock the very item that you need.

Theatrical Drapes

J&C Joel has been supplying theatrical drapes to all kinds of venues, large and small, for over 30 years. Whether your requirement is for a school hall, a simple black box theatre, glitzy cabaret stage or a grand auditorium, the J&C Joel sewing team is at your service.

Different styles of curtains suit different venues. These illustrations, and the information on the following pages, will act as a guide, but if you would like any further assistance, please telephone our sales team 01422 833 835 or email sales@jcjoel.com

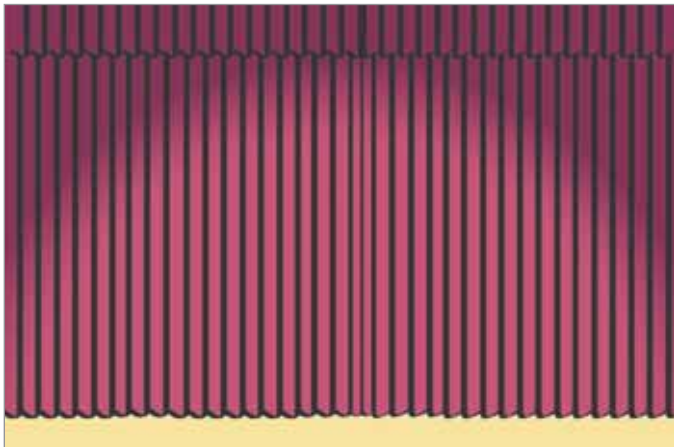
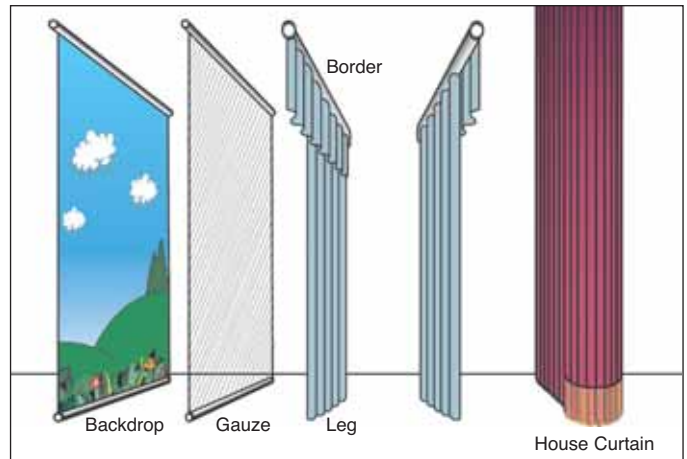

Traveller curtain

The traveller or bi-parting curtain comprises two sections which are suspended from a track and which open and close from centre to off-stage. The most commonly used curtain style, it typically has 50-100% fullness and is generally manufactured in velvet when used as a front curtain or wool serge when on stage.



Tableau Curtain (also known as a Wagner, German or Butterfly)

A pair of pleated or gathered curtains, the curves (swag) are obtained by sewing rings on the back of each curtain diagonally from the lower on-stage edge to the upper off-stage edge. A cable or line threaded through the rings lifts the curtain open. Large or heavy drapes may need motorised rigging.

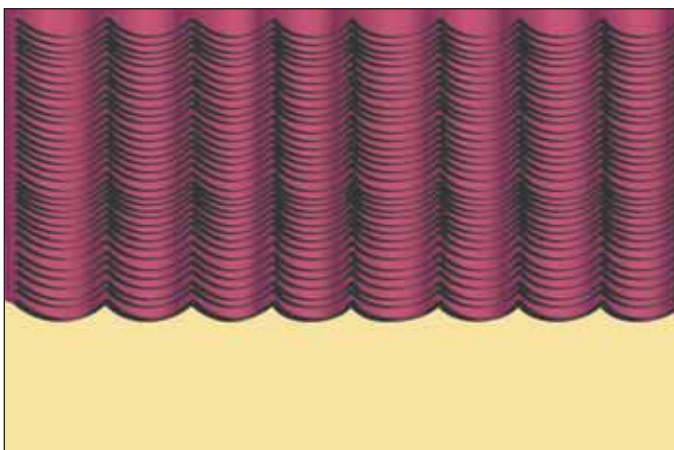

Austrian Curtain - Reefer

Very ornate, with vertical and horizontal fullness sewn into the horizontal pleated swags. Raised evenly by multiple vertical lift lines between each pleat. Usually made with ornate fabrics to give the luxurious look of the grand opera houses.



Venetian Contour Curtain

With the appearance of a simple pleated curtain when down, the Venetian offers a choice of lifts: raise all the multiple vertical lift lines together for an even scalloped bottom edge, or adjust the lift lines for a more elaborate look, as shown.

Top Finishes

Webbing and Eyelets

Cotton or polypropylene tape with 20mm nickel eyelets, typically at 300mm centres (ties optional).

Ties Top

The most common finish. A cotton or polypropylene tape with 25mm cotton tape ties. A coloured centre tie is standard.

Tab Hooks

Metal hook sewn onto cotton or polypropylene tape. The strongest method of attaching drapes to particular types of tracking systems. Ideal for large drapes.

Golf Bag Hooks

Metal hook sewn onto cotton or polypropylene tape. The strongest method of fixing drapes to particular types of tracking systems or static lines. Used when track runner needs curtain to hang under runner eye.



Eyelets



Ties top



Coloured centre tie



Rufflette



Tab hooks



Golf bag hooks

Bottom Finishes

Chain Weight Base

The typical finish for most drapes. The chain enables the curtain to hang properly and allows the drape to flow smoothly when opening and closing. Heavier drapes may not need additional weights.



Chain weight base

Pipe Pocket

Used on cycloramas, scrims and flat drapes. Allows for the addition of a pipe or batten, which gives a flat straight edge.



Pipe pocket without skirt



Pipe pocket with skirt

Decoration

J&C Joel is regarded as the world's best manufacturer of custom appliqué drape decoration. Specialising in the restoration and duplication of heritage works, J&C Joel has worked on a number of the UK's Frank Matcham theatres, which are considered to be among the best examples of heritage theatres in the world.

"J&C Joel were instrumental in restoring the authenticity of the auditorium at the Coliseum."

David Wright, partner, RHWL Architects

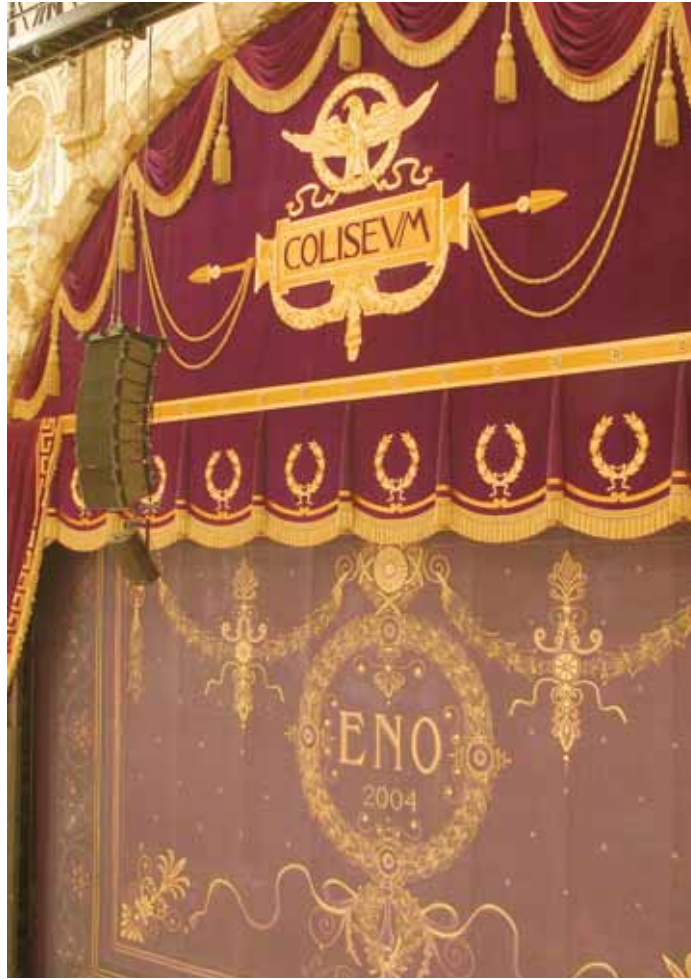

Left: The pelmet at London's Coliseum is over 18m wide and 10m long and weighs almost half a ton. The golden eagle was recreated using several different satins, the fabric being turned and reversed to give different light reflection. The eagle's feet and wings are separate to the main torso, and each leaf on the wreaths is individual, with veins stitched into it. Each ribbon is a separate item, as are both wreaths and the padded COLISEVM sign.

"J&C Joel understand our market and consequently are efficient,

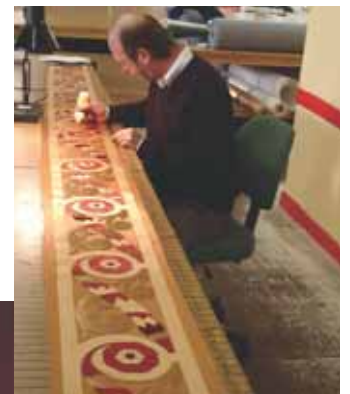



Above: Frank Matcham's Belfast Opera House



Left: Frank Matcham's Blackpool Grand

very helpful and have never let us down."

Annette Whitelaw, designer, Scottish Television, Glasgow



Sunderland Empire

"I was really impressed with the level of attention to detail from J&C Joel."

Mel James, technical manager, Sunderland Empire

Legend

Symbols have been used throughout this catalogue to identify, for example, an item's width, weight and length. We have kept the system as simple as possible, but if you have any queries, please do not hesitate to contact us.

Note: Within the limitations of a catalogue, the fabric colours as printed in the following pages are a guide only. Also, we are unable to show every colour in every range – if you have a requirement and do not see it here, please ask.

GENERAL SYMBOLS



Width



Weight



Approx roll length of material in metres/feet.



Approx roll length of tapes in metres.



In addition to colours shown, the fabric can be custom dyed. Minimum quantities apply.



Can sizes for paint, in litres

FLAME RETARDANCY SYMBOLS

For easier recognition we have colour coded the flame retardancy qualities of the fabrics and coatings; fabric product codes are coloured appropriately.



NDFR

Non Durably Flame Retardant: chemically treated with a water solution and if wetted in any way should be retreated.



DFR

Durably Flame Retardant: chemically treated to withstand a number of cleanings.



IFR

Inherently Flame Retardant: woven from fibres with a high flame retardancy and in some cases a chemical treatment is also added as an extra safeguard.



FR

Flame Retardant



Not FR

Not Flame Retardant: no flame retardant treatment.



BS5867

BS5867 Pt2 B is the British Standard for flame retardant fabrics used for curtains and drapes.



BS5852

BS5852 Pt1 is the British Standard for flammability of upholstered composites for seating.

M1

Conforms to French Fire Regulations.

B1

Conforms to German Fire Regulations DIN 4102.

Acoustic Transparent

A lightweight fabric which allows sound to penetrate whilst masking visually. Ideal for sub base speaker openings in a stage.

Black



NDFR
cotton



BS5867



260cm
102"



140 g/m²



50m approx
164ft approx



Black
ACT001

Synthetic Speaker Cloth

Fine weave acoustically transparent fabric that is ideal as covers for cinema wall loudspeakers or where a fine lightweight fabric is required.

Black



NDFR
synthetic



BS5867



137cm
54"



180 g/m²



100m approx
328ft approx



Black
SC001

Wool Speaker Cloth

A durable fabric that allows sound to penetrate whilst masking visually. Ideal for larger drops such as loudspeaker stacks.

Black



DFR
wool



BS5867



150cm
60"



230 g/m²



60m approx
197ft approx

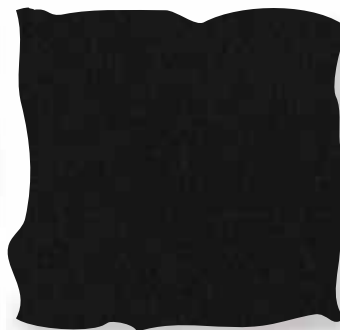

Black
SC002

Acoustic Velvet Velour

A heavy velvet velour backed with an acrylic coating that allows excellent acoustic absorption. Ideal for large exhibition centres when dividing space for different events.

Black



NDFR cotton/
acrylic backing



BS5867



122cm
48"



480 g/m²



50m approx
164ft approx

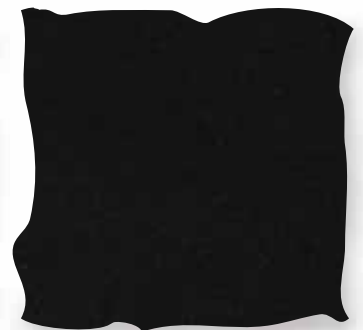

Black
VEL130

For a copy of the test report on the properties of our acoustic fabrics, contact our Sales Department on +44 (0)1422 833 835.

Bolton Twill

A cotton twill for stage and perimeter curtains. Inexpensive, it's ideal for schools, budget productions and event drapes. Good range of matt standard colours. Lighter in weight than wool, it can also be used as a lining fabric.

 9 Colours

 **NDFR** cotton
DFR cotton

 BS5867

 cm 122 150
inches 48 60

 250 g/m² **NDFR**
275 g/m² **DFR**

 100m approx
328ft approx



Beige
BT008

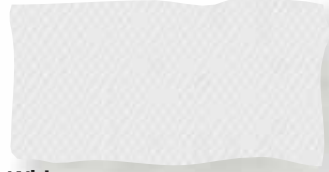

White
BT007; BT016 150cm



Blue
BT009



Green
BT012



Grey
BT006; BT015 150cm
BT024; BT026 150cm



Red
BT010



Burgundy
BT011



Black
BT005; BT014 150cm;
BT023; BT025 150cm



Brown
BT013



St John Bosco's Art College, Liverpool, UK

Please note that all reference numbers refer to 122cm width rolls unless otherwise specified.

Brusan

Brusan is a unique scenic product obtained by laminating aluminium with various textiles to form a fabric without elastic return. It supports its own weight and can be easily shaped and re-shaped. Brusan can be painted and re-painted as each show dictates. Fire retardant to M1.

5 Colours



NDFR
cotton



BS5867, M1



cm	120	140
inches	47	55



Varies



10m approx
33ft approx



White double sided
BRU001 120cm



Gold
BRU013 140cm



Snow White
BRU009 120cm



Silver
BRU014 140cm



Brusan moulds easily round a light framework to form rocks or cliffs.



Natural double sided
BRU005 140cm

Other finishes are available.

For scenic paints, see pages 66 and 67.

The rocks each side of the steps have been formed with Brusan.

Economical, Brusan can be used time and again, as it can be reshaped and painted for the next production.



Cotton Cyclorama Canvas

This theatrical cyclorama cloth can also be used for backdrop, projected images, lighting, effects and painting. The variety of widths available enables the manufacture of large seamless cycloramas.



3 Colours



NDFR
cotton



Not FR
cotton



BS5867, B1

cm
320 420 600 620 1000 1200
inches
126 165 236 244 393 473



220 g/m²



50m approx
164ft approx

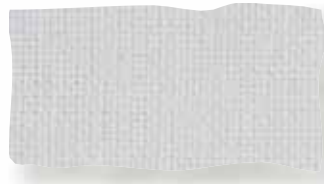

White
CAN022 320cm
CAN045 420cm
CAN024 600cm
CAN027 620cm
CAN029 1000cm
CAN041 1200cm



Black
CAN063 320cm
CAN054 600cm
CAN055 620cm
CAN073 1000cm
CAN074 1200cm



Natural
CAN021 320cm; **CAN023** 600cm; **CAN025** 600cm;
CAN026 620cm; **CAN028** 1000cm; **CAN030** 1000cm;
CAN042 1200cm

Trevira Cyclorama Canvas

The same uses as our cotton cyclorama canvas, but with the added advantage of French M1 and German B1 fire certificates, making it ideal for scenic cloths and cycloramas for European touring shows.

White



IFR
polyester Trevira CS



BS5867, M1, B1



620cm
244"



200 g/m²



50m approx
164ft approx

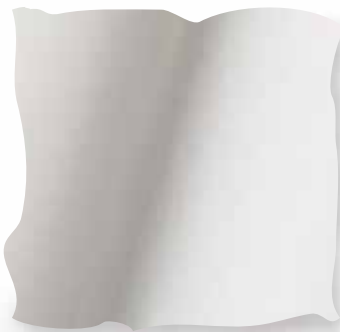

White
CAN043

Casement

An affordable, lightweight cotton fabric offered in an extensive colour range. Used in one off shows and for the exhibition market. Ideal for ceiling drapes and particularly as lining drapes for marquees.



27 Colours



NDFR
cotton



BS5867



cm	122	150
inches	48	60



125 g/m²



100m approx
275 ft approx

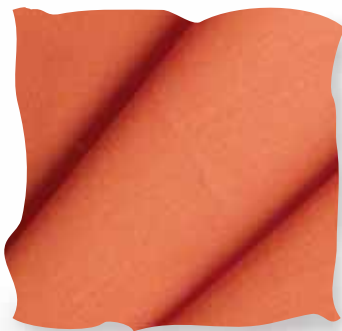

Tango
CAS007



Ivory
CAS003; CAS043 150cm



Ecru
CAS004



Primrose
CAS005

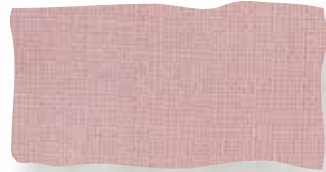

Pink
CAS015



Red
CAS016



Dark Red
CAS017



Rust
CAS010



Coffee
CAS008



Chestnut
CAS009

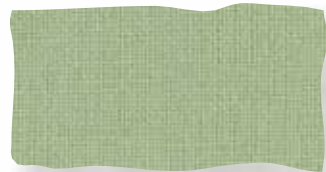

Apple Green
CAS020



Sky Green
CAS019



Mint Green
CAS021



Ice Blue
CAS023

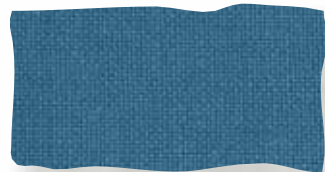

Kingfisher
CAS014



Borage Blue
CAS024



White
CAS001; CAS041 150cm



Dove Grey
CAS026



Battleship Grey
CAS027



Lilac
CAS012



Purple
CAS013



Gold
CAS006



Burgundy
CAS018



Chocolate
CAS011



Forest Green
CAS022

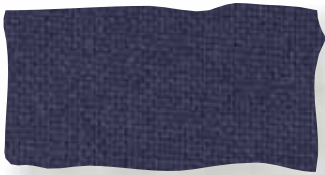

Navy
CAS025



Black
CAS002; CAS042 150cm



Please note that reference numbers refer to 122cm width rolls unless otherwise specified.

Chromakey Cyclorama Canvas

Dyed specifically to suit the TV and film chromakey process, which enables special effects via the camera and mixing equipment. This IFR fabric matches to chromakey scenic paints. Major advantage is the 620cm width which allows for seamless cloths. Ideal for TV news studios.

2 Colours



IFR
polyester Trevira CS



BS5867



620cm
244"



200 g/m²



50m approx
164ft approx



Blue Box
PT042

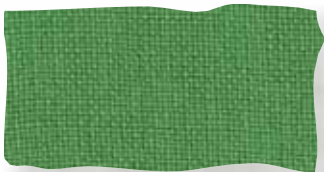

Green Box
PT043

Chromakey Wool Serge

This wool serge is dyed specifically to suit the TV and film chromakey process, which enables special effects via the camera and mixing equipment. Fabric matches to chromakey scenic paints.

4 Colours



DFR
wool



BS5867



150cm
60"



400 g/m²



60m approx
197ft approx

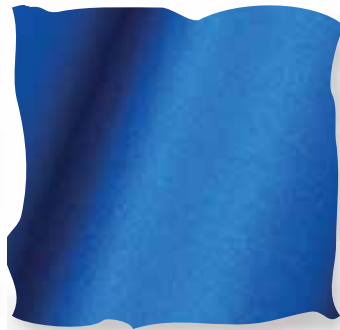

Ultra Blue
WS017



TV Blue
WS016



Chromakey Blue
WS018



Chromakey Green
WS019

Joelastic

A great wide poly stretch with sheen finish. Ideal for small studios and for stretching over frames for an endless number of shapes and designs.

2 colours



DFR
83% polyamide/
17% elastane



BS5867, M1, B1



200cm
80"



260 g/m²



50m approx
164ft approx



Chromakey Blue
JOS007

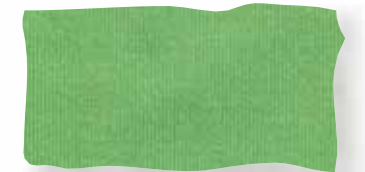

Chromakey Green
JOS008

Molton

A brushed cotton fabric, available up to 300cm wide. These standard chromakey colours are an economical choice.

2 Colours



NDFR
cotton



BS5867, M1, B1



cm 200 300
inches 80 120



310 g/m²



60m approx
197ft approx



Chromakey Green
MOL008



Chromakey Blue
MOL003

Video Paints

Ultimatte

The approved Ultimatte Paint System, designed in conjunction with Ultimatte technical staff. Super Blue is a purer blue designed for use in film production. Can be used on nearly any surface.

Vinyl Acrylic



3.79

- 57201 Ultimatte Blue
- 57211 Ultimatte Green
- 57221 Ultimatte Super Blue

Chroma Key

Specifically formulated to provide high luminance values and colour saturation for keying effects. High-build, one coat coverage for nearly any surface.

Acrylic



3.79

- 57101 Chroma Key Blue
- 57111 Chroma Key Green

Digicomp Paint

Precision crafted to allow seamless compositing for film, video and digital use. For use on a wide variety of substrates.

Vinyl Acrylic



3.79, 18.95

- 57050 DigiComp Blue
- 57070 DigiComp Green

TV Paint

Specially formulated for the sensitive contrast requirements of standard TV systems. TV Black and White are completely intermixable to achieve intermediate greys. Matt, non-reflective finish; allows for easy touch up. The White is a neutral grey that meets specifications for 60% reflectance; the rich, matt Black meets specifications for 3% reflectance.

Acrylic



3.79

- 573516 TV White
- 574017 TV Black

Chromakey Tape

500 Matt MagTape

A matt version of the original gaffer tape with a minimal 1.9% reflection ratio, making it perfect for TV and film studios.

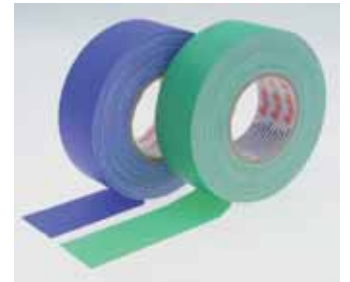

50mm



50m approx

- MMCB50** Chromakey Blue
- MMCG50** Chromakey Green



Scottish Television, Pacific Quay, Glasgow, UK

Other chromakey products include Rosco's Digicomp tape and fabric, plus their Chroma Key cloth. For full details see the J&C Joel Price List.

Joel Sparkle

A lightweight cotton with a glitter finish, ideal for exhibition and party design companies. With a B1 fire certificate, it allows a wonderful sparkle effect when lit.

10 Colours



NDFR cotton with glitter



BS5867, B1



cm	140	280
inches	55	110



165 g/m²



30m approx
98ft approx



Black
GLI028; GLI029 280cm



White
GLI020; GLI021 280cm

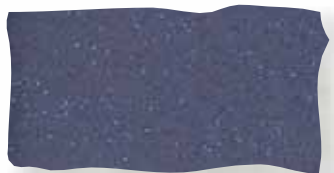

Blue
GLI022; GLI023 280cm



Turquoise
GLI036; GLI037 280cm

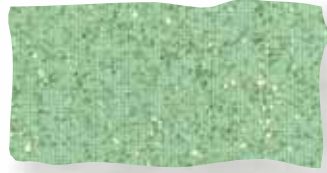

Green
GLI024; GLI025 280cm



Brown
GLI026; GLI027 280cm



Yellow
GLI030; GLI031 280cm

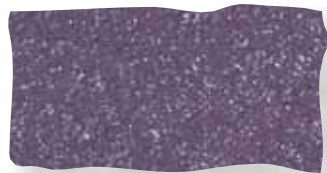

Purple
GLI038; GLI039 280cm

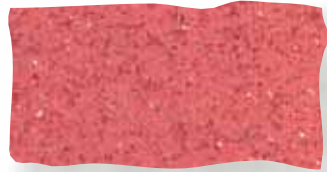

Red
GLI034; GLI035 280cm

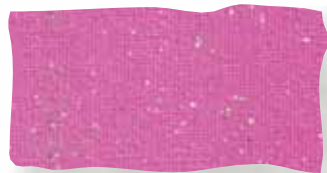

Pink
GLI032; GLI033 280cm

Liquid Lamé

A polyester foil available in a good range of colours. Reflects light extremely well, making it ideal for glitzy, designer shows.

6 Colours



NDFR polyester



BS5867



112cm
44"



125 g/m²



100m approx
328ft approx



Silver
LL002



Gold
LL001



Red
LL003

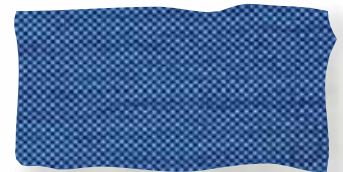

Royal Blue
LL004



Green
LL005

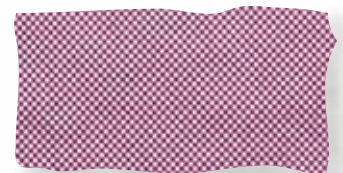

Purple
LL006

All reference numbers for Joel Sparkle refer to the 140cm width unless otherwise specified.

Shimmerlite

A fine, lightweight, wide gauze with Lurex thread running through it.

6 Colours



IFR polyester Trevira CS with Lurex



BS5867



330cm
130"



95 g/m²



50m approx
164ft approx



Gold
SHI001



Gold/Silver
SHI003



Silver
SHI002

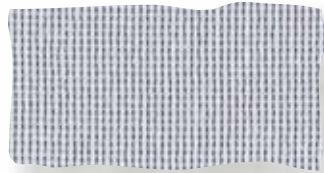

Blue
SHI004

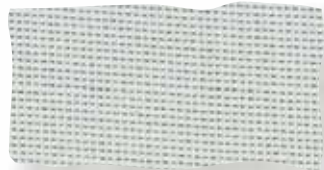

Green
SHI006

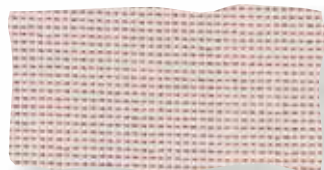

Red
SHI005

Glacier

A lightweight fabric with an iridescent finish. Delicate in looks, strong in use.

Iridescent



IFR

60% polyester Trevira CS
40% polyester



BS5867



330cm
130"



42 g/m²



50m approx
164ft approx



Iridescent
GLA001

Laser Gauze

The name says it all – this gauze gives the most brilliant results when doing a laser show.

Silver



IFR

polyester Trevira CS



BS5867



300cm
120"



22 g/m²



50m approx
164ft approx



Silver
LG001

M1 Studio Canvas

The M1 is ideal for TV studio cloths. It has a softer handle than the wide width canvas and the added advantage of a French M1 fire certificate.

Natural, White



White
CAN082 420cm
CAN088 770cm



Natural
CAN081 420cm
CAN087 770cm

Cotton Canvas

The ideal weight and weave for scenic painters, this has a stiffer handle than the wide width canvas and a slightly different weave. Provides another option for the expertise of the scenic artist.

Natural, White



White
CAN092



Natural
CAN091

Wide Width Canvas

The ideal weight and weave for scenic painters, this theatrical cotton canvas sizes and paints perfectly. The wider canvasses are ideal for seamless painted backdrops.

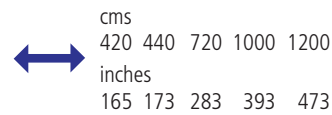

Natural
CAN013 420cm
CAN015 440cm
CAN017 720cm
CAN019 1000cm
CAN200 1200cm



Black
CAN070 1000cm



White
CAN014 420cm
CAN016 440cm
CAN018 720cm
CAN020 1000cm
CAN022 1200cm

Digital Canvas

The best canvas for digital printing; reproduction is brilliant, with no bleeding. Available in a range of larger widths to suit large format print machines.

White



IFR
clevyl



BS5867, M1



cm	320	520
inches	126	205



320 g/m²



50m approx
164ft approx



White
CAN031 320cm
CAN032 520cm



Detail from backdrop, right

Digital Flag Knit

A lightweight flag material ideal for indoor/outdoor graphic drops and suitable for solvent, UV flatbed and sublimation printing.

White



IFR
polyester Trevira CS



BS5867, M1



305 cm
120"



110 g/m²



100m approx
328ft approx



White
PTD001



Dimalan

Ideal fabric for dimming light transmission. With a colour woven to a black backing, it is ideal for windows and exhibitions where a near blackout is required. Also used as a drape fabric for main and onstage curtains in conference centres.

24 Colours

 **IFR**
modacrylic

 BS5867

 cm 127 150
inches 50 60

 g/m² 270 270

 metres 50 100 approx
feet 164 328 approx



Bilberry
DIM043; DIM019 150cm wide

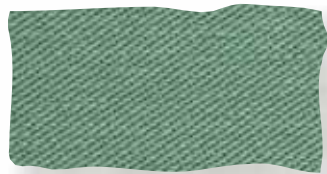

Apple
DIM034



Copper
DIM044



Russet
DIM048



Apricot
DIM028

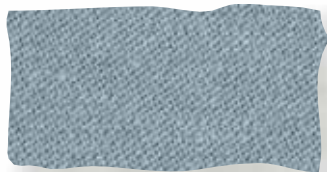

Ice Blue
DIM029



Terracotta
DIM035



Beige
DIM040



Jade
DIM046; DIM022 150cm



Ruby
DIM039



Buttercup
DIM032



Kingfisher
DIM041; DIM017 150cm



Moss
DIM042



Claret
DIM047



Opal
DIM025



Sea Green
DIM038



Coral
DIM031



Royal
DIM033; DIM009 150cm

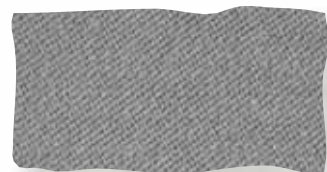

Slate
DIM037

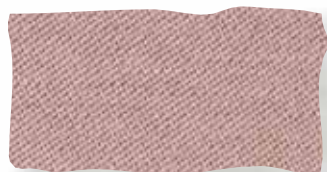

Damask
DIM027



Nutmeg
DIM036



Black
DIM045; DIM021 150cm

Please note that reference numbers refer to 127cm width rolls unless otherwise specified.



Filled Cloth

The industry standard for cycloramas for TV, film and theatre. The cloth comes up to 1180cm wide and is ideal for seamless cloths. The weave allows for an excellent tool for lighting designers as it "softens" the light.



5 Colours



NDFR
cotton



BS5867,M1, B1

cm	320	580
	914	1180
inches	126	228
	360	465



245 g/m²



38m approx
124 ft approx



Black
FIL005

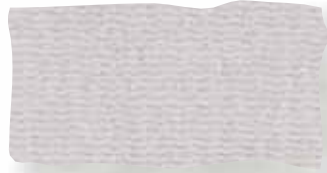

Grey
FIL002



Natural
FIL004



Sky Blue
FIL003



White
FIL001
FIL010 320cm
FIL006 580cm
FIL007 1180cm



Solstice Arts Centre, Navan, Ireland



MRTV, Myanmar

All reference numbers refer to 914cm width rolls unless otherwise specified.

Display Felt

Manufactured primarily for the exhibition industry, Display Felt is ideal for dressing trade show stands and lining set pieces such as drum risers. A wide range of colours enable good corporate stand design.

33 Colours



NDFR
60% viscose/40% wool



BS5867



183cm
72"



150 g/m²



56m approx
183 ft approx



Pink
DF005



White
DF033



Gold
DF030

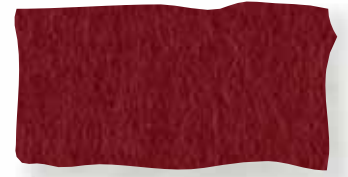

Cherry
DF001



Cream
DF036



Dahlia
DF027



Cerise
DF004



Dark Cream
DF037



Orange
DF028

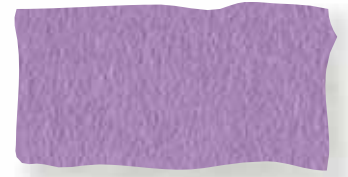

Lavender
DF015



Beige
DF013



Candy
DF007



Purple
DF016



Lemon
DF032



New Flesh
DF014

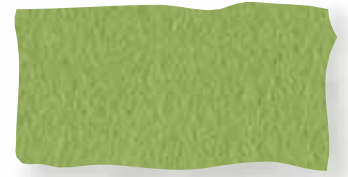

Leaf
DF026



Olympian Yellow
DF031



Red
DF003

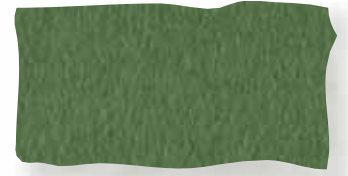

Apple
DF025



Fiesta
DF029



Flame
DF002



Holly
DF024

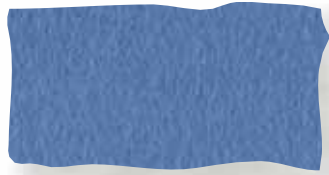

Mid Blue
DF020



Silver
DF034



Peacock Blue
DF021

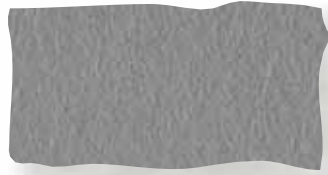

Grey
DF039

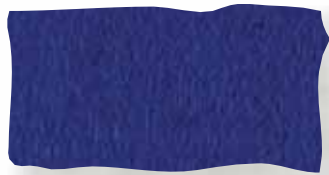

Royal
DF019

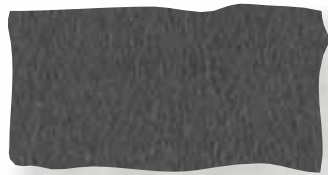

Dark Grey
DF035



Navy
DF018



Black
DF017



New Fawn
DF012



Chestnut
DF009



Dark Brown
DF008

Leather Grain

Make a leather-look sofa out of cardboard – easy with this leather grain effect fabric. Ideal for set pieces, exhibitions, etc.



White
LGR002



Yellow
LGR005



Red
LGR003



Blue
LGR004

5 Colours



DFR
PVC



B55867



137cm
54"



330 g/m²



50m approx
164ft approx



Black
LGR001

Crushed Suede

An ideal fabric for the exhibition market and for covering set pieces and props, this gives a luxurious suede effect finish. Excellent range of colours.

17 Colours



NDFR
flocked cotton



BS5867



140cm
55"



278 g/m²



metres 50 to 60 approx
feet 164 to 197 approx



Royal
CS007



White
CS021



Light Grey
CS014



Coffee
CS005



Cream
CS018



Dove Grey
CS022



Black
CS017



Palamino
CS002

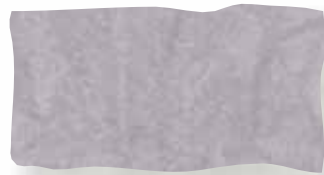

Silver Grey
CS015



Stone
CS019



Purple
CS009



Sky Blue
CS020



Granat
CS011



Muscari
CS006



Rouge
CS010



Marine
CS008

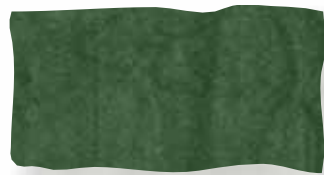

Tarn Green
CS012

Sharkstooth Gauze

An 8 point cotton scrim used for lighting effects. Light the scrim from the front at an oblique angle, with the scene behind totally dark, and the scrim appears opaque, rendering the scene behind invisible. Reverse the lighting - light the scene behind and dim the front lights - and the scrim becomes transparent, revealing the upstage scene. The tooth is typically vertical although it works horizontally. Can be scenically painted.



8 Colours



NDFR
cotton



BS5867, M1, B1



cm
610 914 1097 1200
inches
240 360 432 473



100 g/m²



58m approx
190ft approx

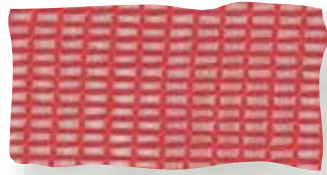

Red
ST013 1097cm

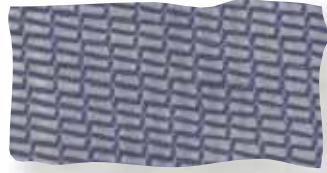

Navy
ST012 1097cm



Sky Blue
ST003 914cm; ST009 1097cm

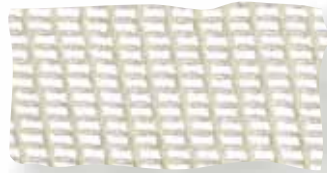

Natural
ST005 914cm; ST010 1097cm

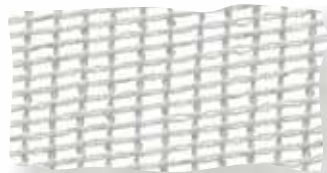

Eastern Grey
ST008 1097cm



White
ST026 610cm; ST001 914cm;
ST006 1097cm; ST014 1200cm



Black
ST028 610cm; ST004 914cm;
ST011 1097cm; ST016 1200cm



Western Grey
ST002 914cm; ST007 1097cm;
ST015 1200cm

8pt Trevira Sharkstooth

This IFR sharkstooth has a slightly different texture to the cotton version. It is ideally suited to humid venues and loudspeaker stacks for outdoor concerts.

2 Colours



IFR
Trevira



BS5867



1097cm
432"



100 g/m²



58m approx
190ft approx



White
ST019



Black
ST020

6pt Sharkstooth

The most traditional sharkstooth weave. Widely used in Europe, it has a larger point aperture than the standard 8 point.

2 Colours



NDFR
cotton



BS5867, M1



1150cm
453"



100 g/m²



58m approx
190ft approx



White
ST017

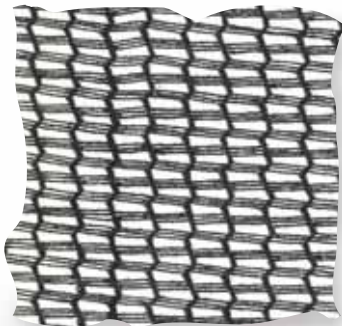

Black
ST018

Fine Gauze

The small weave of fine gauze is ideal for film diffusion cloths. It can also be used in conjunction with other gauze types to create depth and contrast.

2 Colours



NDFR
cotton



BS5867



cm 366 732
inches 144 288



60 g/m²



35m approx
115ft approx



White
FG001 366cm; **FG003** 732cm

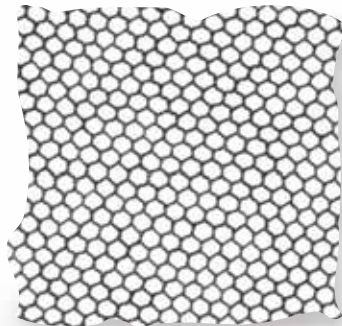

Black
FG002 366cm; **FG004** 732cm

Double Fine Gauze

New gauze proven to achieve an f-stop of f1.1; avoids the moiré effect obtained when using two layers of fine gauze.

Black



NDFR
cotton



BS5867



610cm
240"



77 g/m²



00m approx
000ft approx



Black
TN000

Tiger Netting

Unique square 6x6mm hatch weave for specialised lighting effects.

2 Colours



NDFR
cotton



BS5867



980cm
386"



80 g/m²



45m approx
148ft approx



White
TN001



Black
TN002

Scenic Gauze

A hexagonal weave that is larger than sharkstooth. Excellent as a lighting diffuser, it is also used in conjunction with sharkstooth scrim to create the illusion of depth.

3 Colours



NDFR
cotton



BS5867



cm 914 1200
inches 360 473



40 g/m²



metres 55 50 approx
feet 180 164



White
SG001 914cm wide/55m long

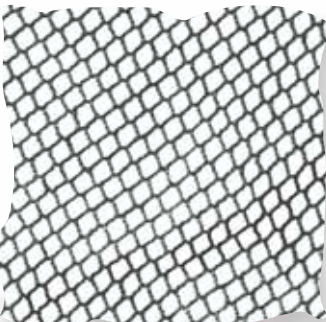

Black
SG002 914cm wide/55m long;
SG008 1200cm /50m long

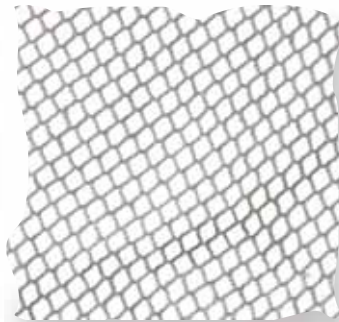

Grey
SG003 914cm wide/55m long

Heavy Bobbinet

The larger hexagonal weave of heavy bobbinet is used to achieve depth and contrast while diffusing light, typically when combined with other gauze types.

3 Colours



NDFR
cotton



BS5867



950cm
374"



60 g/m²



25m approx
82ft approx



White
BN001



Black
BN003



Grey
BN002

Square Gauze

A 3x3mm open weave. Create depth or use with other gauzes to create different lighting effects.

-  3 Colours
-  **NDFR**
cotton
-  BS5867, M1, B1
-  1097cm
432"
-  110 g/m²
-  60m approx
197ft approx



White
SQG001

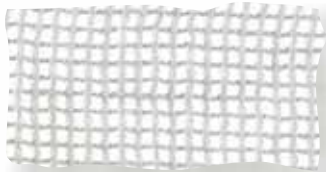



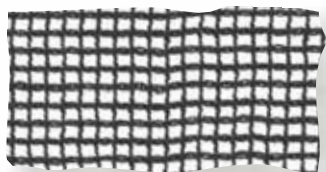

Grey
SQG002



Black
SQG003

Scenery Netting

Large 1" net that is used to stabilise cutouts in scenic cloths by giving body to the opening.

- 2 Colours
-  **IFR**
-  BS5867
-  914cm
360"
-  30 g/m²
-  22m approx
72ft approx







White
SN001



Black
SN002

Reflective Gauze

Creates a shimmering effect: used to diffuse light and add depth, giving a silver sheen as a result.



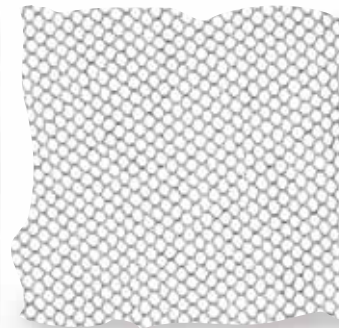

- Silver
-  **NDFR**
38% cotton/
62% Metlon Rexor
-  BS5867, M1, B1
-  850cm
335"
-  80 g/m²
-  45m approx
148ft approx



Silver
REF001

Euro Gauze

A denser weave than sharkstooth. Has a cross thread that gives a different lighting effect compared to traditional gauzes.

- White
-  **NDFR**
cotton
-  BS5867
-  1097cm
432"
-  100 g/m²
-  50m approx
164ft approx



White
EG001

Linings

J&C Joel offers a range of lining fabrics, from total blackout to sateen. Eclipse is particularly good for windows as it has a UV backing. Linings both protect curtains and give a nice finished backing.

Premier Blackout

Black



DFR
polyester



BS5867



150cm
60"



290 g/m²



50m approx
164ft approx

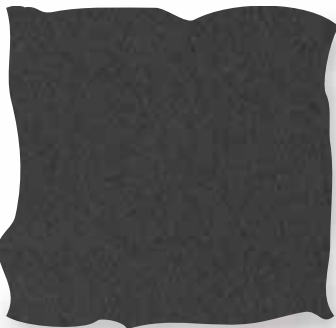

Black
PB001

Sateen Lining

2 Colours



NDFR cotton
DFR cotton



BS5867



137cm
54"



150 g/m²



90m approx
295ft approx



Black
LIN002 LIN003



Cream
LIN001 LIN004

Eclipse Lining

2 Colours



DFR 52% polyester/
48% cotton



BS5867



137cm
54"



300 g/m²



50m approx
164ft approx



Cream
LIN007



White
LIN005

Molton

A brushed cotton fabric, available up to 300cm wide. Very economical, so ideal for budget drapes, masking fabric and scenery.

4 Colours



NDFR
cotton

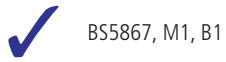

BS5867, M1, B1



cm	200	300
inches	80	120



310 g/m²



60m approx
197ft approx



Black
MOL001 200cm; MOL002



Blue
MOL003



Grey
MOL004



White
MOL005



Green
MOL008

Reference numbers are for 300cm wide rolls unless otherwise stated.

Trevira Molton

An IFR 3m wide molton which is brushed one side only. Ideal for rental drapes as it can be washed, and the most popular fabric for starcloth shells, whether fibre optic or LED.

Black



IFR
polyester Trevira CS



BS5867, M1, B1



300cm	120"
-------	------

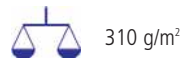

310 g/m²



60m approx
197ft approx



Black
MOL010

USA Commando Cloth

Not called Commando Cloth for nothing! This masking duvetyn is a film industry workhorse, used for masking, shoot off drapes and backdrops.

Black



NDFR
cotton



BS5867



137cm	54"
-------	-----



400 g/m²



91m approx
100yds approx



Black
COM001

Jomeleon

A sheer two tone Trevira CS voile. The fabric's iridescent characteristics 'come alive' when it is pleated, making it ideal for specialist drapes such as festoon/reefer and swags & tails. Can be used for most sheer applications.

9 Colours



IFR polyester
Trevira CS



BS5867



300cm
120"



65 g/m²



60m approx
197ft approx



Blue
JOM610B



Red
JOM609R

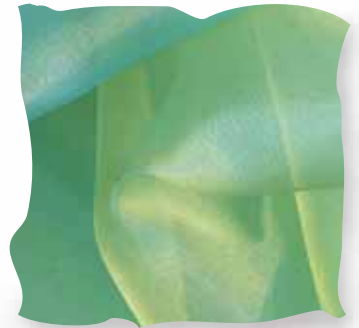

Yellow
JOM609Y



Blue
JOM600B

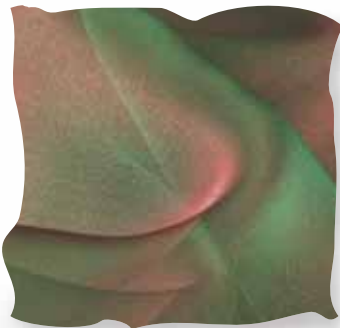

Red
JOM610R



Yellow
JOM613Y



Blue
JOM604B



Red
JOM611R



Yellow
JOM607Y

Jap Silk

A natural silk that comes in a wonderful range of colours. The silk drapes beautifully and has a luxurious look. Ideal for presentation drapes and lining marquees.

32 Colours



NDFR silk



BS5867



140cm
55"



36 g/m²



46m approx
151ft approx

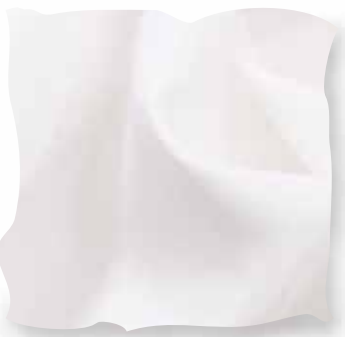

White
JS001



Ivory
JS002



Poppy
JS019



Duck Egg
JS036



Cream
JS003



Claret
JS016



Forget-me-not
JS037



Buttercup
JS011



Burgundy
JS017



Cornflower
JS038



Marigold
JS008



Garnet
JS018



Turquoise
JS039



Camel
JS010



Lipstick
JS014



Sapphire
JS041



Tangiers
JS009



Lilac
JS044



Kingfisher
JS040



Vermilion
JS020



Lavender
JS045



Marine
JS043



Peppermint
JS026



Steel
JS033



Lime
JS048



Pewter
JS034



Emerald
JS031



Black
JS047



Military
JS029



Coffee
JS023



Chocolate
JS024



Chinchilla
JS022



Muslin

Cheesecloth – light, open weave and inexpensive. Available in three colours. Ideal for event decorating and dressing theatre sets.

3 Colours



NDFR
cotton



Not FR
cotton



BS5867

↔	cm	122	600	1000
	inches	48	236	393

⚖	50 g/m ² NDFR and Not FR
	75 g/m ² NDFR

📦	metres	60*	100**	approx
	feet	197	393	approx

* 600/1000cm widths only
**122cm width only



Natural

MUS001 122cm wide/50 g/m²
MUS003 122cm wide/50 g/m²
MUS006 600cm wide/75 g/m²
MUS008 1000cm wide/75 g/m²



Black

MUS005 122cm wide/50 g/m²



White

MUS002 122cm wide/50 g/m²
MUS004 122cm wide/50 g/m²
MUS007 600cm wide/75 g/m²
MUS009 1000cm wide/75 g/m²

Acoustic Felt

This inexpensive acoustic matting is used to dampen and absorb sound in venues and set pieces. It is not usually visible to the audience.

2 Colours



NDFR 70% jute/
30% wool



Not FR 70% wool/
30% jute



BS5867

↔	137cm
	54"

⚖	880 g/m ² NDFR
	1420 g/m ² Not FR

📦	25m/82ft approx NDFR
	11m/36ft approx Not FR



Multi
AF001



Fawn
AF002

Hessian

An ideal fabric for set and prop making. Used to cover set pieces and to add texture to prop pieces.

Natural



NDFR jute



Not FR jute



BS5852

↔	183cm
	72"

⚖	325 g/m ² NDFR
	300 g/m ² Not FR

📦	50m approx
	164ft approx



Natural
HES001 HES002

Scrim

An inexpensive fabric for dressing sets and props. Ideal for covering wire frame set pieces; allows base coat primers such as Rosco to be applied prior to scenic painting.

Natural



Not FR
jute



91cm
36"



85 g/m²



50m approx
164ft approx



Natural
SC005

Interlinings

Interlining is an essential component of curtains when you require a luxury drape with improved appearance. It provides excellent acoustic properties and also thermal properties for rooms such as performance spaces.

Wadding

White



DFR
polyester



BS5867



122cm
48"



205 g/m²



20m approx
66ft approx



White
WAD001

Synthetic (Bump)

White



IFR
polyester



BS5867



137cm
54"



200 g/m²



50m approx
164ft approx



White
INT001

Heavy Cotton (Bump)

Natural



NDFR
85% cotton/
15% mixed fibres



BS5867



137cm
54"



410 g/m²



45m approx
148ft approx



Natural
INT002

Orion

Orion is a 96% blackout fabric and similar to Dimalan in construction, but with the colour woven in both sides. Ideal for window curtains and drapes that will be seen from both sides. Used in sports halls, conference centres and schools.

21 Colours

 **DFR**
polyester

 BS5867

 137cm
54"

 240 g/m²

 50m approx
164ft approx



Ruby
OR015

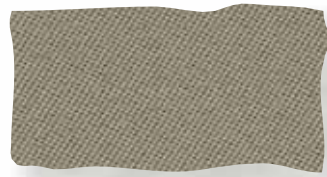

Beige
OR016



Bilberry
OR019

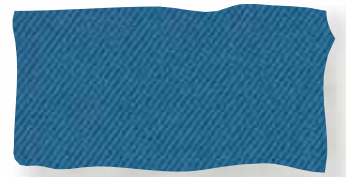

Opal
OR001



Apricot
OR004



Claret
OR023



Royal
OR009



Buttercup
OR008

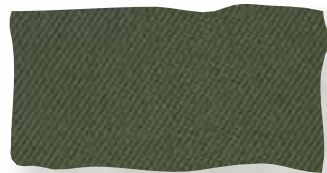

Clover
OR002



Slate
OR013

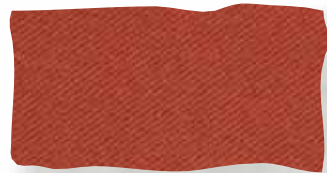

Copper
OR020



Apple
OR010

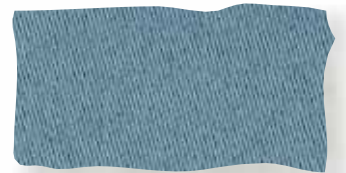

Ice Blue
OR005

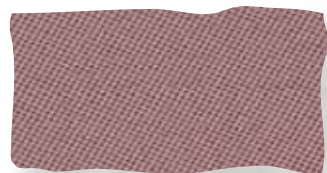

Damask
OR003



Sea Green
OR014



Kingfisher
OR017



Terracotta
OR011



Moss
OR018



Black
OR021



Coral
OR007



Jade
OR022

Linen Flooring

The most traditional fabric for stage floor cloths. Provides excellent layflat quality and suitable for scenic painting. Available with or without a pvc backing.

Natural



Not FR
linen



200cm
80"



700 g/m²
600 g/m²



50m approx
164ft approx



Natural with PVC backing
LIN050 700 g/m²



Natural
LIN051 600 g/m²

Brown Flax

A darker floor cloth which is used when painting is not required. The flax is also strong and ideal for the rigours of stage cloths.

Brown



Not FR
flax



220cm
86"



520 g/m²



50m approx
164ft approx



Brown
FLA002

Walking Canvas

As the name suggests, an excellent weight cotton canvas for stage floor cloths. The walking canvas is a durable, heavy duty canvas designed for the rigours of performers and ideal for scenic painting.

Natural



Not FR
cotton



cm	275	335
inches	108	132



320 g/m²









50m approx
164ft approx



Natural
CAN001 275cm
CAN002 335cm

Polyester Trevira

The ideal fabric for lining marquees, tent and nightclub ceilings. This polyester Trevira is a strong, inherently flame retardant fabric used throughout the industry, including TV, film, theatre and events.

-  22 Colours
-  **IFR**
Polyester Trevira CS
-  BS5867
-  cm 150 183
inches 60 72
-  68 g/m²
-  100m approx
328ft approx



Royal
PT019



White
PT001; PT031 183cm



Gold
PT005



Pink
PT012



Ivory
PT002; PT030 183cm

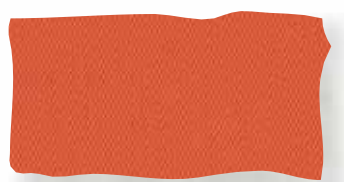

Orange
PT022



Lilac
PT016



Lemon
PT003



Red
PT013



Sky
PT018



Acacia Yellow
PT004



Burgundy
PT014



Silver
PT015



Champagne
PT006



Mint
PT009



Purple
PT017



Apricot
PT007



Green
PT010



Navy
PT020



Salmon
PT008



Bottle
PT011



Black
PT021

Reference numbers refer to 150cm wide rolls unless otherwise specified.



Voile

Sheer translucent fabric used in the event and theatre industry to make beautiful flowing drapes, swags and ceiling linings. Lighting designers will enjoy working with this voile, which can be lit to stunning effect.

10 Colours



IFR
polyester Trevira CS



BS5867, M1, B1



cm
150 300 420 520
inches
60 120 165 205



50 g/m²



60m approx
197ft approx



White
VOI001
VOI018 520cm
VOI010 300cm
VOI013 420cm



Champagne
VOI012 300cm



Gold
VOI003



Orange
VOI004



Red
VOI005; VOI025 300cm



Purple
VOI006; VOI021 300cm



Royal
VOI007; VOI027 300cm

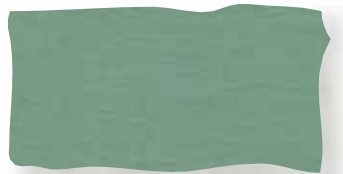

Green
VOI009



Silver
VOI002

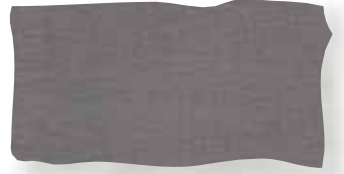

Black
VOI008
VOI011 300cm
VOI014 420cm

Mousseline

An excellent sheer decorative fabric for the event and exhibition market due to its wide width. Ideal for lining ceilings, marquees and Christmas grottos. Available with or without a slub.

White



IFR
polyester Trevira CS



BS5867



cm 150 300 420
inches 60 120 165



75 g/m²



50m approx
164ft approx



White
MOU001 150cm
MOU002 300cm
MOU003 420cm



White (with slub)
MOU004 300cm

Reference numbers refer to 150cm wide rolls unless otherwise specified.

Projection Screens

A complete range of front and rear projection screen surfaces, including Perforated and Non-Perforated matt white for front projection. Front and rear projection screens include Twin White, blues and greys for event and exhibition use. J&C Joel provides a manufacturing service to make projection screens to any reasonable size, which are sonically welded to give a near invisible seam.

9 Colours



DFR
PVC



BS5867

cm

140 200 220 240 395 590



inches

55 79 86 94 155 232



500 g/m²



metres 20 62 approx
feet 65 203 approx



Perforated White
PVC045 140cm / 60m



Non-perforated White
PVC044 220cm / 50m

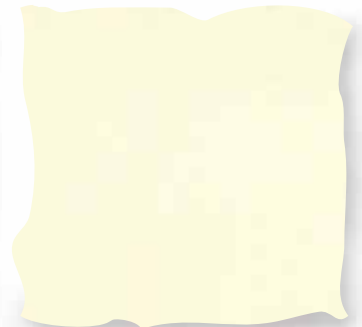

Cream
PVC064 240cm / 60m



Fog
PVC030 220cm / 60m



Midnight
PVC059 200cm / 60m



Sky Blue
PVC058 200cm / 60m



Grey
PVC042 240cm / 60m

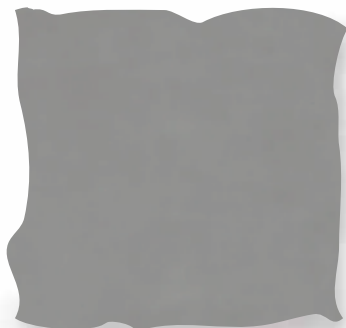

Hi-Gain Grey
PVC061 200cm / 60m
PVC062 395cm / 20m
PVC063 590cm / 20m



Twin White
PVC055 200cm / 60m
PVC056 395cm / 20m
PVC057 590cm / 20m

Technical data sheets available on request.



PUFC Waterproof

Showerproof nylon fabric. Ideal for protection bags and outdoor covers. Note: if stitched, seams will need to be sealed.

12 Colours



DFR
nylon



BS5867



148cm
58"



114 g/m²
198 g/m²



80m approx
262 ft approx



Black
PUF001; PUF002 198 g/m²



Yellow
PUF006 198 g/m²



Orange
PUF010 198 g/m²



Red
PUF007 198 g/m²



Violet
PUF014 198 g/m²



Royal Blue
PUF009; PUF004 198 g/m²



Dark Grey
PUF008 198 g/m²



Grey
PUF011

Reference numbers for PUFC Waterproof refer to 114 g/m² weight rolls unless otherwise specified.

PVC Coated Fabric

Ideal for tarps, waterproof drops and equipment covers. An excellent range of colours. Heavyweight and very durable.

13 Colours



DFR
PVC



BS5867



152cm
61"



580 g/m²



50m approx
164 ft approx



Black
PVC020



Yellow
PVC011



Orange
PVC018



Red
PVC014



Cerise
PVC022



Violet
PVC024



Blue
PVC001



Green
PVC006

Stage Satin

This heavyweight, opaque stage satin not only drapes beautifully but also has a luxurious sheen.

5 Colours



NDFR 57% viscose/
43% cotton



BS5867



144cm
57"



250 g/m²



50m approx
164ft approx



Silver
SS001



Royal Blue
SS006



Burgundy
SS004



Black
SS007



Gold
SS003

Polyester Trevira Satin

A luxurious satin Trevira. Ideal for swags and reefer style curtains. Hangs beautifully.

7 Colours



IFR
polyester Trevira CS



BS5867



150cm
60"



110 g/m²



100m approx
328ft approx



White
PTS001



Ivory
PTS002



Royal
PTS007



Purple
PTS005



Gold
PTS003



Red
PTS004



Black
PTS006

Cotton Sheeting

Lightweight canvas, up to 600cm wide, which can be painted to create backdrops or used for projection.

3 Colours



NDFR
cotton



BS5867

↔	cm	150	183	260
	inches	60	72	102
		108	118	236



190 g/m²



50m approx
164ft approx



White
SHE012 600cm



Black
SHE001 150cm
SHE003 183cm
SHE006 260cm



Bleached White
SHE002 183cm
SHE004 274cm
SHE010 300cm

Cotton Calico

A good quality inexpensive cotton calico for pattern making, lightweight backdrops and sets.

Natural



NDFR
cotton



Not FR
cotton



BS5867

↔	cm	183	300	600
	inches	72	118	236



190 g/m²



50m approx
164ft approx



Natural
CAL001 183cm
CAL002 183cm
CAL003 300cm
CAL004 600cm

Polyester Sheeting

A narrow IFR sheeting that is washable and hard wearing. A great fabric for the exhibition and marquee industries.

White



IFR
polyester



BS5867

↔	183cm
	72"



145 g/m²



50m approx
164ft approx



White
PS001

Ultra Stretch

An excellent stretch cotton providing a matt finish. Ideal for shapes and frames where a two way stretch is required. Great range of colours.



8 Colours



DFR
92% cotton/
8% elastane



BS5867



175cm
69"



200 g/m²



60m approx
197ft approx



Royal
US006



White
US001



Gold
US004



Orange
US009



Green
US008



Red
US005



Purple
US007



Black
US002

Joelastic

A great, wide poly-stretch with sheen finish that comes in a range of fabulous colours. Ideal for stretching over frames for an endless number of shapes and designs.



8 Colours



DFR
83% polyamide/
17% elastane



BS5867, M1, B1



200cm
80"



260 g/m²



50m approx
164ft approx



Black
JOS002



White
JOS001



Champagne
JOS003



Grey
JOS004



Red
JOS006



Blue
JOS007



Burgundy
JOS005



Green
JOS008

For creative ideas,
see page 71.

Twotone

This decorative Trevira fabric has a wide range of applications, including cinemas, conference centres and municipal buildings. Also ideal for the event industry.



14 Colours



IFR
polyester Trevira CS



BS5867



178cm
70"



180 g/m²



100m approx
393 ft approx



Grey
TT010



Beige
TT002

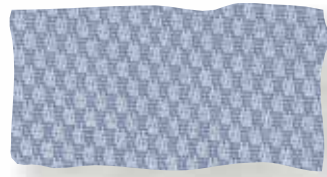

Sky Blue
TT004



Antique Gold
TT009

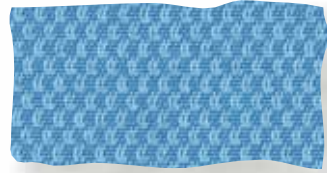

Turquoise
TT013

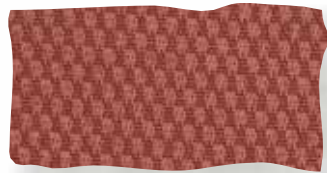

Tan
TT011

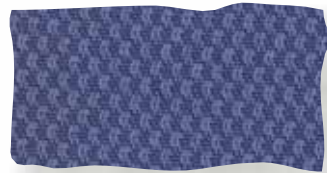

Royal Blue
TT014

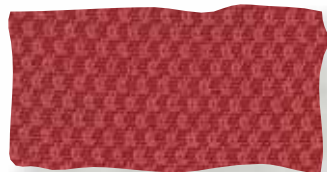

Port
TT007



Airforce
TT015



Plum
TT003



French Navy
TT005

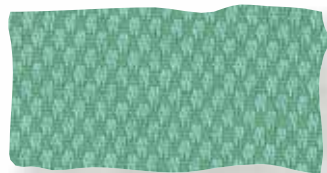

Emerald Green
TT006



Black
TT016





Forest Green
TT001

Velvet Velour

A traditional stage cotton velvet for front of house and valance theatre curtains in a wide choice of colours. Used in venues from schools to national tours and productions.

 33 Colours

 **NDFR**
DFR
cotton

 BS5867

 122cm
48"

 375 g/m² **NDFR**
395 g/m² **DFR**

 55m approx
180ft approx



Plum
VEL003 VEL037



Fawn
VEL015 VEL049



Clover
VEL005 VEL039



Ginger
VEL020 VEL054



Mocha
VEL016 VEL050



Scarlet
VEL034 VEL068



Paprika
VEL021 VEL055



Mink
VEL017 VEL051



Port
VEL002 VEL036



Cognac
VEL022 VEL056



Chocolate
VEL023 VEL057

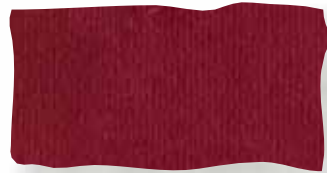

Mulberry
VEL006 VEL040



Onyx
VEL029 VEL063



Gold
VEL018 VEL052



Maroon
VEL007 VEL041



Thyme
VEL030 VEL064

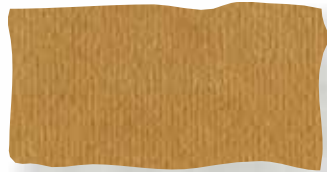

Amber
VEL019 VEL053



Damson
VEL008 VEL042

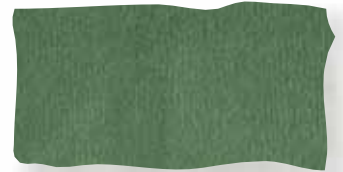

Leaf
VEL031 VEL065

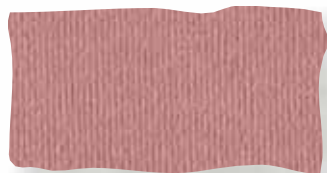

Pink
VEL013 VEL047



Raspberry
VEL004 VEL038



Holly
VEL032 VEL066



Mallard
VEL028 VEL062



Jade
VEL026 VEL060

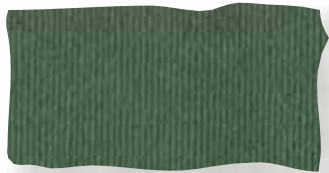

New Bottle
VEL033 VEL067

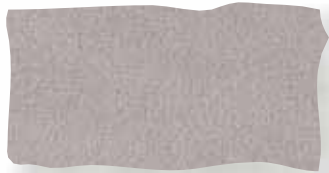

Silver
VEL024 VEL058



Slate
VEL025 VEL059



Sky
VEL027 VEL061



Marine
VEL010 VEL044



Oxford Blue
VEL011 VEL045



Midnight Blue
VEL012 VEL046



Purple
VEL009 VEL043



Black
VEL001 VEL035

NEW!

York Velvet – the widest heavyweight velvet available. For colours see  in Velvet Velour.

4 Colours



NDFR
cotton



BS5867



178cm
70"



525 g/m²



30m approx
98ft approx

- Plum** VELW004
- Marine** VELW002
- Midnight** VELW003
- Black** VELW001

M1 Velvet Velour

A wider velvet, so bigger curtains will require less metreage. Available in the seven most popular colours, M1 velvet has a more durable finish than standard velvet velour and the added advantage of a French M1 fire certificate.

7 Colours



NDFR
cotton



BS5867, M1



140cm
55"



378 g/m²



50m approx
164ft approx

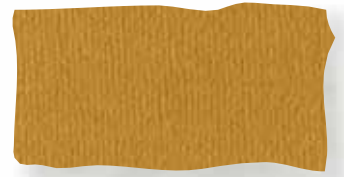

Gold
VEL125



Port
VEL084



New Bottle
VEL093



Marine
VEL083



Plum
VEL085



Royal Blue
VEL092



Black
VEL082

Vegas Velour

A heavy opaque stage velvet in a premium, extra wide width suitable for heavy luxurious drapes. Designed specifically to be used as drapes for the most prestigious theatres, opera houses and auditoria.



8 Colours



NDFR
cotton



BS5867
Available in M1, B1



150cm
60"



565 g/m²



30m approx
98ft approx



Gold
VEL163



Natural
VEL166



Scarlet
VEL164



Angel Flame
VEL160



Wine
VEL165



Royal Blue
VEL167



Navy Blue
VEL162



Very Black
VEL168

Heavy Velvet Velour

The traditional stage cotton velvet, this opaque velvet is ideal for conference centres, universities and regional theatres.



10 Colours



NDFR
cotton



BS5867



122cm
48"



520 g/m²



50m approx
164ft approx



Navy
VELH009



True Gold
VELH003



Brick
VELH006



Red
VELH004



Claret
VELH005



Purple
VELH007



Royal
VEL008

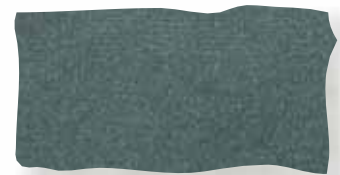

Bottle
VELH010

*DFR available on request -
minimum quantities apply.*



Grey
VELH002



Black
VELH001

Cabaret Sparkle Velvet Velour

A stage velvet with a glitzy Lurex thread which sparkles under stage lights; can be used in the same way as traditional velvet.

13 Colours



NDFR
cotton



BS5867



138cm
54"



250 g/m²



50m approx
164ft approx



Purple
VEL072



Natural
VEL077

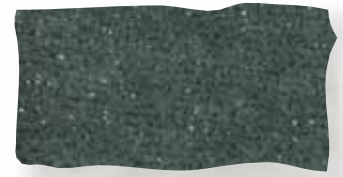

Green
VEL081



Gold
VEL078

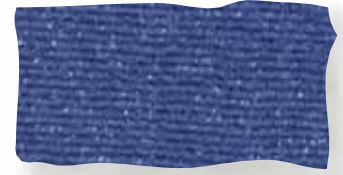

Royal
VEL073



Rust
VEL075

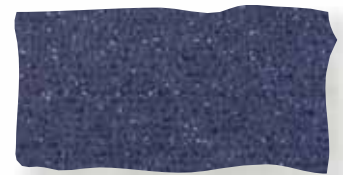

Navy
VEL074

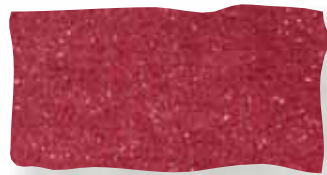

Wine
VEL070



Grey
VEL079

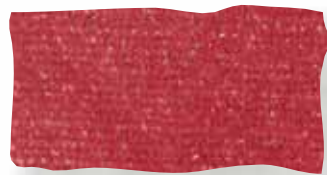

Red
VEL069

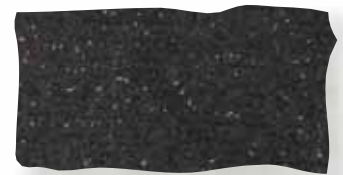

Black
VEL076

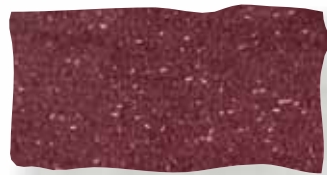

Burgundy
VEL071



Ocean
VEL080

Super Wool Serge

The super wool is the industry standard ideal for touring shows and hire drapes. Popular for traditional onstage masking and perimeter curtains, this weight is ideal for school halls, working clubs, regional theatres, etc.

Black



DFR
wool



BS5867



150cm
60"



525 g/m²



60m approx
197ft approx



Black
WS003

Heavy Wool Serge

The workhorse of theatrical fabrics, it is also ideal for touring shows and hire drapes. Durable, strong and with good acoustic properties, this is the most popular fabric for traditional onstage masking and perimeter curtains.

Black



DFR
wool



BS5867



150cm
60"



625 g/m²

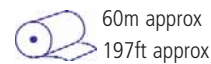

60m approx
197ft approx



Black
WS004

Kilo Serge

By the pure nature of its weight, the kilo serge offers the best acoustic properties of any wool serge, so is ideal for flat drapes where acoustic absorption is key. A test report on its acoustic properties is available on request.

Black



DFR
wool



BS5867



150cm
60"



1000 g/m²



60m approx
197ft approx



Black
WS022

Taylor's Sparkle

Wool serge with a metallic thread. Use for curtains when a cabaret or glitzy mood, together with the strength of wool serge, is required.

Black/Gold
Black/Silver

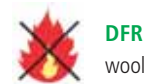

DFR
wool



BS5867



150cm
60"



470 g/m²



60m approx
197ft approx



Black/Silver
TAY001

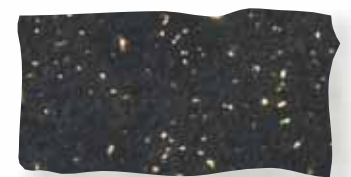

Black/Gold
TAY002

Coloured Wool Serge

This coloured serge is the most popular fabric for perimeter and production curtains. Durable, strong and with good acoustic properties, it comes in a range of stock colours.



16 Colours



DFR wool



BS5867



150cm
60"



400 g/m²



60m approx
197ft approx



Plum
WS006



Slate
WS013

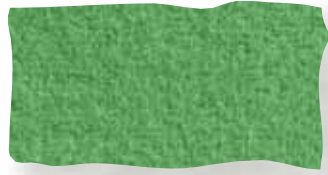

Emerald
WS014



Natural
WS020



Gold
WS010



Cognac
WS011



Mole
WS012



Scarlet
WS005



Bottle
WS015



Marine
WS007



Midnight Blue
WS009



Oxford Blue
WS008



TV Blue
WS016



Chromakey Blue
WS018



Chromakey Green
WS019



Ultra Blue
WS017

Joelmat

The most versatile dance and event flooring there is. Wider than most at 200cm and with a great range of colours, it is perfect for not only ballet and modern dance but also the stage, all types of event flooring, exhibitions, concerts, car launches and showrooms: in fact anywhere a colourful floor is needed. Can be digitally printed.

10 Colours



DFR
vinyl



BS4790 Flooring



200cm
80"



1340 g/m²



25m approx
82ft approx



Grey
JM007



Brown
JM003



Pale Blue
JM001



White
JM004



Red
JM002



Green
JM006



Royal
JM005



Black
JM008



High Gloss Black
JGL002



High Gloss White
JGL001

PVC Stage Mat

Matt semi-permanent, reversible floor for dance, including ballet.

2 Colours



DFR
PVC



BS4790 Flooring



150cm
60"



1680 g/m²



40m approx
131ft approx



Black/White
DFL001



Black/Grey
DFL002

Use ProJoin tape to join Joelmat or PVC Stage Mat - see page 70.

Staging

In use in the performing arts since 1994, Maltbury Staging systems are used by theatres, tv and film companies, orchestras and choirs, schools and colleges, sports centres and churches. The basis of each system is modularity, to give ease of use, versatility, compactness and reliability.

Metrodeck

This is a great all-purpose modular staging system. Smart and versatile, the height is altered simply by changing the legs, so it can be used for all kinds of platforms, from flat or raked stages to seating tiers, catwalks and rostra. With the strength and durability of heavier systems, Metrodeck is easy to handle and has a slim profile, making it particularly suitable for venues where storage space is at a premium.

Standard Metrodeck specifications

Frame	Steel
Finish	Black powder-coating
Top	18mm birch ply
Acoustic layer	FR felt
Legs	2" steel tube
Weight (2mx1m)	42kg
Weight (1mx1m)	25kg
Loading	5kN/m ²
Safe unbraced	<1m (steel legs)
Stacking depth	115mm
Connections	Velcro strap



Stage Machinery

J&C Joel offers a complete package of stage machinery, to complement its expertise in stage drapes. The Installations Department offers its services on a worldwide basis, with completed projects not only in the UK and Ireland, but also the Middle East and Far East. Design, project management, manufacture and installation services are available for counterweight systems, orchestra lifts, safety curtains, motorised winch systems and overstage grids. Technical specifications are available on request.



Strule Arts Centre, Omagh, Northern Ireland

Pilewind Winches

In addition to the items listed, customised units to accommodate different capacities, speeds and pick-ups are available on request.

- Electric 125kg**
Fixed Speed – 4mm SWR
- | | |
|--------|--------|
| JPW016 | 3 line |
| JPW017 | 4 line |
| JPW018 | 5 line |

- Electric 250kg**
Fixed Speed – 5mm SWR
- | | |
|--------|--------|
| JPW021 | 3 line |
| JPW022 | 4 line |
| JPW023 | 5 line |
| JPW024 | 6 line |

- Electric 500kg**
Fixed Speed – 6mm SWR
- | | |
|--------|--------|
| JPW031 | 3 line |
| JPW032 | 4 line |
| JPW033 | 5 line |
| JPW034 | 6 line |

- Manual 250kg**
Self Sustaining – 5mm SWR
- | | |
|--------|--------|
| JPW041 | 3 line |
| JPW042 | 4 line |
| JPW043 | 5 line |

- Manual 500kg**
Self Sustaining – 6mm SWR
- | | |
|--------|--------|
| JPW051 | 3 line |
| JPW052 | 4 line |
| JPW053 | 5 line |
| JPW054 | 6 line |

- Control**
- | | | |
|--------|-------------------------------|---------------|
| JPW001 | Up, down, plus emergency stop | 6kg |
| JPW002 | Manual Handle | 2kg |
| JPW003 | Drill - 110v | 10kg |
| JPW004 | Drill Adaptor | 0.50kg |

- Remotes**
- | | | |
|--------|--------------|------------|
| JPW006 | with E Stop | 5kg |
| JPW007 | keyed E Stop | 5kg |



Solstice Arts Centre, Navan, Ireland





Alley Arts Centre, Strabane, Northern Ireland



Counterweight system: Carriage Works, Leeds, UK



Counterweight lines and cyclorama: Solstice Arts Centre, Navan, Ireland

Pulleys

In addition to the items listed, customised units to accommodate different capacities, speeds and pick-ups are available on request

Cable Pulleys

BS7950 Pt 1
max. 6mm SWR

150mm dia.

JPUL001 1 way

JPUL002 2 way

JPUL003 3 way

JPUL004 4 way

JPUL005 5 way

200mm dia.

JPUL011 1 way

JPUL012 2 way

JPUL013 3 way

JPUL014 4 way

JPUL015 5 way

Hemp Pulleys

max 16mm rope

150mm dia.

JPUL021 1 way

JPUL022 2 way

JPUL023 3 way

JPUL024 4 way

JPUL025 5 way

200mm dia.

JPUL031 1 way

JPUL032 2 way

JPUL033 3 way

JPUL034 4 way

JPUL035 5 way

JPUL051 76-210 Angles

JPUL052 229-305 Angles

JPUL053 Clips



Alley Arts Centre, Strabane, Northern Ireland

Curtain Controllers

Designed to suit all cable driven stage curtain tracks, these curtain controllers have a 10m maximum travel which allows for an overlap track up to 18m wide. Custom sizes are available and can be manufactured to suit larger drapes.

JCJ10S Single speed with onboard control.

JCJ10V Variable speed onboard control



Track Systems

Silent Gliss is the leading global supplier of 'Contract Duty' motorised and manual curtain and blind systems, offering the very best in terms of quality, design, technology, service and individuality. A dedicated team of highly skilled and experienced professionals develop new products as well improve existing ones, with innovation being inspired and driven by demanding customer needs.

Silent Gliss

Silent Gliss track is suitable for situations where a domestic style track is required, such as lightweight curtains for windows and doorways.



Variable Acoustics

Triple E track systems have proved their reliability over thousands of performances around the world. The company has won many awards for its innovative products and provided solutions for complex automated track systems. Today, Triple E and J&C Joel together have become one of the leading designers and suppliers of variable acoustic systems.

Variable acoustics are a key part of modern performance space design, with the acoustic solution having great bearing on the architectural design. Opera, symphony and chamber music, plus amplified sound, require very different environments, yet many venues are expected to be multi-purpose. In order to provide the different acoustic qualities needed by each type of performance, variable acoustics, in the

form of banners or curtains, are being utilised.

Acoustic banners

An acoustic banner consists of two layers of wool serge, hanging vertically and separated by horizontal slats. Raised and lowered vertically, they have been described as being in the style of a Venetian blind with a layer of fabric at the front and back.

Acoustic curtains

Acoustic curtains travel horizontally on tracks, in a similar way to curtains used on stage, usually behind the seating and against the walls of the space. They have historically presented the problem of storage when not in use, but the use of Triple E's Chaintrack has provided the solution and can be seen in use in many notable venues: read more on page 61.

Below: Lawrence Hall, Royal Horticultural Halls, London
A multi-purpose exhibition and event venue, Lawrence Hall needed acoustic banners that would also double as blackout blinds. J&C Joel and Triple E designed and supplied 56 acoustic roller blinds at the clerestory windows on each side of the Hall, plus a further seven acoustic banners, the longest of which is 15m. The installation uses 2,535sq m of acoustic fabric, which was dyed specifically to match the walls.

Acoustic test reports for banners and curtains are available on request.





Acoustic banners, similar to Venetian blinds in design, in Hall Two.



Tracking a curtain into a pocket behind the walls of Hall One.

The Sage Gateshead (above)

An iconic building in Tyneside, England, The Sage Gateshead is an inclusive, open-for-everyone music venue, with two concert halls, Northern Rock Foundation Hall for rehearsal and performance and a 25 room Music Education Centre. The venue offers a wide range of music, from classical pieces, choral works and 18th century chamber music to folk, jazz, rock, pop and solo artists. The acoustic requirements for each are completely different, so variable acoustics were among the highest priorities. Hall One, with a capacity of 1650, is the largest of the two concert halls and uses retractable acoustic curtains, as does Northern Rock Foundation Hall, whereas the unusual design of Hall Two called for acoustic banners. J&C Joel supplied and manufactured a total of 153 drapes, which weighed an impressive 6 tons. The main picture shows the acoustic curtains in Hall One. These retract back into pockets behind the walls of the auditorium.

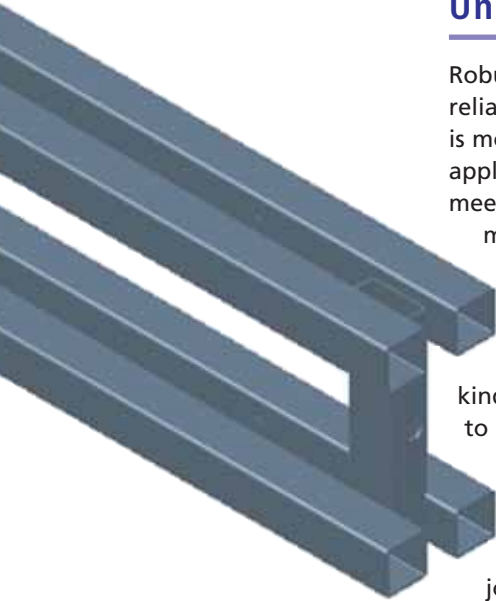

Unitrack

Robust, versatile and reliable, Triple E's Unitrack is most suited to heavy duty applications. As well as meeting the demands of all major venues, Unitrack is particularly useful for touring applications. It has been used extensively in all kinds of shows from rock to opera.

The unique fabricated I beam, with its simple one bolt and four spigot jointing system, provides a 'jam-free' running surface. Ball raced runners and nylon pulley sheaves add to the smooth, silent operation.

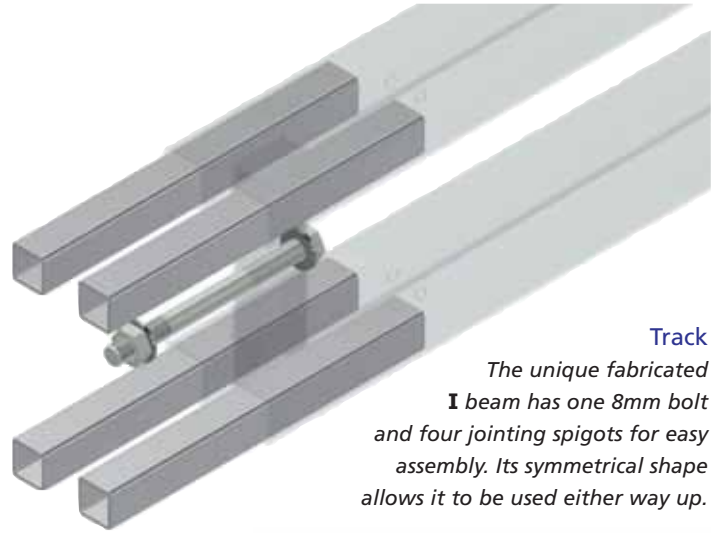

Track
The unique fabricated I beam has one 8mm bolt and four jointing spigots for easy assembly. Its symmetrical shape allows it to be used either way up.

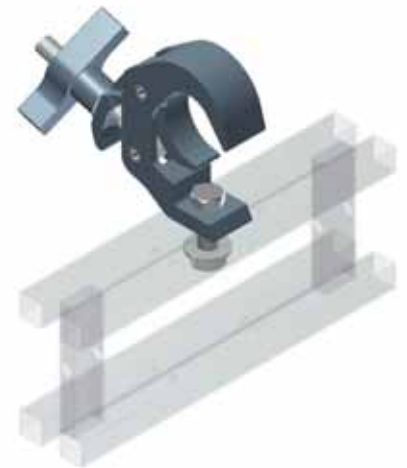

Suspension
The versatile slot design enables positioning of hanging points anywhere along the track's length, including eye bolts for steel rope, studding, girder clamps or purpose made brackets.

Unibeam

An extruded aluminium, black anodised equivalent of Triple E's Unitrack. Strong enough to be used as a suspension beam, it is particularly suitable where curved sections are required. Ideal for heavy duty applications in permanent installations.



Track
Unibeam is available in 6.1m lengths and can be pre-rolled to order down to a radius of 2m. Joining and alignment is achieved with pre-drilled steel plates and grub screws.

Scenery Carrier
All the master and slave runners for straight and curved tracks from the Unitrack range can be used, as well as the Unibeam heavy duty scenery carrier.

Runners

Nylon wheels encase precision bearings. Rubber buffers provide silent stacking. Runners can be removed or added at any point along the track. A range of runners and scenery carriers is available. The rearfold accessory may be added to enable curtains to stack offstage rather than from centre.

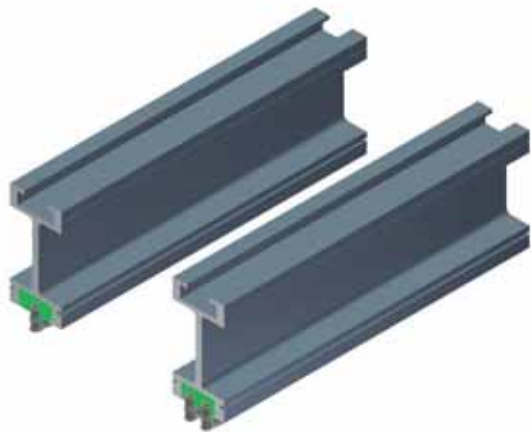

Chain Drive

By the addition of the Chaintrack insert, Unibeam can carry exceptional loads with extreme accuracy.



Chaintrack

Using duplex chain instead of rope to run and stack curtains, Chaintrack enables radii of just 30mm and turns of 180°. It is, literally, Triple E's most flexible system. Use for medium to heavy duty applications where stacking areas are challenging or as a solution for non-conventional applications.

Each Chaintrack system is custom designed. Its standard components are the track and a selection of sprockets. All the necessary platework, guides, motor and controllers are designed and specified for each particular project.



Key Features

- The chain is rigid and the curtain remains flat when drawn offstage, enabling an image or pattern to remain in view.
- It is possible to run the drape around to the reverse side, enabling double sided curtains to be used.
- By creating a continuous loop, a constantly moving backdrop can be achieved.
- There is no drive slippage with Chaintrack, so driving an absolute encoder from the gearbox or sprocket makes it totally reliable and precise, capable of re-creating exact effects and positions time and again.
- By using parallel tracks of the appropriate length, the curtain can be stacked flat in a storage area just a fraction of the length of the curtain itself.

E Rail

Extruded, black anodised aluminium track for any location where all but the heaviest duty stage curtains are required. Small profile and ball raced nylon runners make E-Rail almost silent, ideal for small stages such as those on cruise ships, in conference centres, schools and hotels.



Suspension

The continuous top slot allows flexibility of location for suspension fittings and will take hook clamps or 8mm studding; bolts into channel nut. 10mm or 12mm studding can be used with an intermediate bracket.

Runners

A full range of master and slave runners for straight or curved sections is available. Ball raced nylon wheels enable easy operation, while rubber buffers give silent stacking.



3Way

Aimed at venues with a need for a robust, medium-duty track that is easy to install and operate.

It meets the needs of architects and designers who want a discreet track, by virtue of the fact that the cording is hidden from view. It is not suitable for scenery.

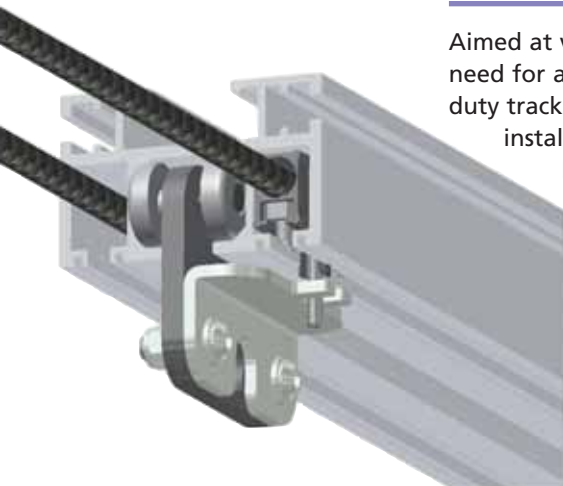

2Way

Related to the 3Way track, this is designed for lightweight curtains, or where a heavy duty domestic track may be suitable, but with the additional requirement of reliability and easy installation. Ideal for where space is at a premium, or for pubs, clubs and smaller venues. Also useful as a cyc track in small TV, photographic and drama studios. Manual, walkalong system, with no facility for cording.



T60

Established in 1898, Hall Stage is believed to have supplied equipment to every theatre in the UK and for thousands of stages, television and film studios throughout the world. This T60 Curtain Track is a reliable, dependable, high quality track meeting the exacting requirements of any stage. Designed with the entertainment industry in mind, T60 can be supplied with switch points, reverse curves, banjo ends and swivel arm carriers as standard. It can be used for rear-folding and beam tracked systems and a vast range of scenery and drape motion applications.

Suitable for electric drives, hand winches, handline or walkalong operation, the versatile T60 Curtain Track can be assembled to meet any configuration.

Shown here is an indication of a system's components: every system is assembled to order. Call our Sales Department on 01422 833 835 for quotation for a complete tracking system to suit your venue.

Carriers



0542 Runner Ballraced



0517 Carrier Ballraced for Swivel Arm



02132 Runner Plain Wheeled

Pulleys



1187 Return Pulley



1188 Pulley Handline Head



1189 Pulley Cable Head

Fixings



03136 Clip Tube Fixing 48mm Barrel



03453 Clip Girder Fixing 75 - 150mm Flange



03753 Universal Fitting

Curved Track Haul



08382 .5m radius x 90°

Curved Track Walk



05911 2m radius x 90°

Straight Section



00586 3m



Barrels and Fittings



As well as proprietary items, J&C Joel can also manufacture custom fittings on request. The products shown here, which are among a wide range of ancillaries offered for rigging systems, are always in stock.

Flyrail Cleats

FCL001	450mm
FCL002	385mm
FCL003	300mm

Universal Clamps

UC011	48mm x M12
UC012	48mm x M12 (Black)
UC013	38mm x M8

Hanging Clamps

HC021	48mm with ring
HC022	48mm SWL 75kg with Ring Black

Wall Brackets

WB031	Pipe to Wall Bracket 300mm 'Stand off'
WB032	Pipe to Wall Bracket 100mm 'Stand off'
WB033	Ceiling Saddle 75mm 'Stand off'

Aluminium Barrel

BA051	48.3mm OD Pipe
-------	----------------

Steel Barrel

SB061	48.3mm OD Pipe
-------	----------------

Brace Weights

BW041	Square	15kg
BW042	Round	15kg



Brace Weight



Flyrail Cleat



Universal Clamp



Hanging Clamp



Aluminium Barrel



Steel Barrel



Wall Bracket

Fibre Optics

Fibre optic drapes are manufactured to order and are available in a selection of designs or a totally random pattern, as well as a range of colours and fabrics. Fibre optics, colour wheels and light sources are also available to buy.



- FIB001 0.5mm fibre
- FIB002 0.75mm fibre
- FIB003 1mm fibre
- FIB004 1.5mm fibre
- FIB005 2mm fibre
- LS001 75w light source/240 volt with Colour & Twinkle wheel
- WHE001 Extra Colour/Twinkle/Clear Wheels
- FER001 Ferrules

Ropes

Designed for manual hauling, this range has ropes to suit all standard pulleys, including J&C Joel's own brand. All ropes are operator friendly, having been manufactured specially to prevent rope splinters. The Chatham Hemp is particularly Health & Safety conscious, as it does not emit any loose fibres during operation.

Black Braided Cord

- ROP001 6mm
- ROP002 8mm

Jute

- ROP006 No 4 6mm
- ROP007 No 5 7mm
- ROP008 No 6 8mm
- ROP009 No 8 10mm

Chatham Hemp

- ROP016 10mm
- ROP017 12mm
- ROP018 16mm
- ROP019 18mm

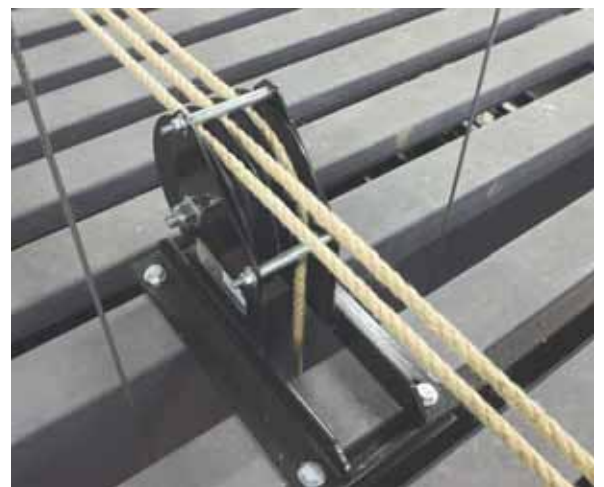

Wire Ropes

These steel wire ropes and wire grips are designed to be used on the J&C Joel range of pilewind winches and most motorised winch systems. The range includes both 7x19 steel and 6x19 fibre core 5mm and 6mm SWL. Different size cores are available on request.

Fibre Core

- WR001 5mm dia Galvanised wire rope, 6x19 construction
- WR002 6mm dia Galvanised wire rope, 6x19 construction

Steel Core

- WR005 5mm dia Steel Core, 7x19 construction
- WR006 6mm dia Steel Core, 7x19 construction
- NAV1226541

Grips

- WR011 Cable Grip DIN1142 5mm
- WR012 Cable Grip DIN1142 6mm



Rope Lock

Standard theatre rope lock with lockdown plastic jaw to prevent damage to counterweight hauling ropes. The operating brake has a capture clip which reduces the possibility of vibrating loose.

- ROP026 Polyurethane Rope Lock
- ROP027 Steel Rope Lock



PAINT

Supersaturated Roscopaint

These brilliant dye-like colours are formulated to be diluted with substantial quantities of water while retaining binder strength and give excellent adhesion to most scenic surfaces including muslin, plastics

and metal. Supersaturated dries to a completely matt, non-reflective finish. As well as drops and hard scenery, Supersaturated may be used on rear projection screen and dance floor.

Vinyl Acrylic



- | | |
|--|---|
|  5965 Red |  5986 Raw Umber |
|  5968 Green Shade Blue |  5987 Burnt Sienna |
|  5969 Ultramarine Blue |  5988 Lemon Yellow |
|  5971 Chrome Green |  5989 Turquoise Blue |
|  5972 Emerald Green |  5990 Prussian Blue |
|  5973 Pthalo Green |  5991 Navy Blue |
|  5975 Magenta |  5993 Leather Lake |
|  5977 Spectrum Red |  5994 Grass Green |
|  5979 Purple |  5996 Cerulean Blue |
|  5980 Iron Red |  5997 Hunter Green |
|  5981 Chrome Yellow |  5998 Van Dyke Brown |
|  5982 Yellow Ochre | |
|  5983 Raw Sienna | |
|  5984 Moly Orange | |
|  5985 Burnt Umber | |

Supersaturated Concentrated Bases



- 6002 White
- 6003 Velour Black









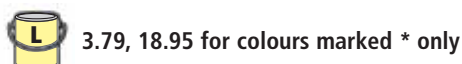











Off Broadway

Rosco's best selling vinyl acrylic paint in a full range of theatrical colours, for use on a wide variety of scenic materials including hard scenery and backdrops. Ready to use, but may be

diluted to stretch your paint budget.

Vinyl acrylic



- | | |
|---|--|
|  5350 White * |  5367 Golden Yellow |
|  5351 White White * |  5368 Purple |
|  5352 Black * |  5369 Magenta |
|  5353 Yellow Ochre |  5371 Pthalo Green |
|  5354 Burnt Umber |  5372 Sky Blue |
|  5355 Raw Sienna |  5373 Pthalo Blue |
|  5356 Burnt Sienna | |
|  5357 Raw Umber | |
|  5359 Ultramarine Blue | |
|  5360 Fire Red | |
|  5361 Deep Red | |
|  5363 Orange | |
|  5364 Emerald Green | |
|  5365 Chrome Oxide Green | |
|  5366 Lemon Yellow | |

Off Broadway Metallic Colours



- | |
|---|
|  5383 Bright Gold |
|  5384 Gold |
|  5385 Silver |
|  5386 Copper |
|  5387 Antique Gold |

Painting Metallic Colours onto flame-retardant fabrics may cause the paint to tarnish and discolour. Test a small area of paint before proceeding with the entire prop.



COATINGS

ClearColour

A revolutionary development in invisible fluorescent coatings. This improved formulation creates designs that are absolutely invisible under normal light, yet glow brightly under ultraviolet light.

Water based



Fluorescent Paint

These vivid colours are brilliant in normal light and glow brightly when bathed in ultraviolet light. White fluoresces a light blue under black light; invisible blue appears milky white under normal light but glows blue in ultraviolet.

Vinyl acrylic



VividFX

A stunning development in fluorescent paints, VividFX offers brilliant fluorescence and one coat coverage and opacity. The exceptional pigments, which glow most brilliantly between 365-380 nanometers, create stunning black light effects and intermix cleanly to provide a wide array of intermediate fluorescent hues. Best applied by spray gun over a white base coat.

Vinyl acrylic

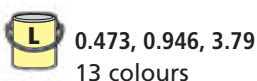

Clear Gloss & Flat Acrylic Glazes

Dilute with water and apply as an overcoat to a painted surface or mix with paints for additional binder strength. Compatible with all Rosco's scenic paint systems and most other water extendable paints. They also serve as a binder for dry pigments and bronzing powders.

Acrylic

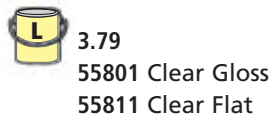

ColourCoat

High gloss finish for use on most scenic surfaces as well as metal, wood, concrete and brick. An excellent choice for decks and floors due to its high abrasion resistance. Dries to the touch in one hour.

Water based acrylic enamel



Tough Prime

Covers just about any surface, including PVC pipe, aluminium, foams and concrete floors, as well as wood and foam core. This quick drying primer dries to a tough, durable coating excellent for both interior and exterior use.

Water based acrylic emulsion

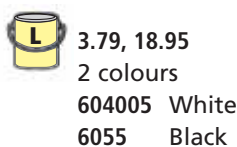

Crystal Gel

Non-toxic material which provides a clear, plastic-like coating on virtually any surface used in modern stagecraft. It air dries quickly – usually within hours – to a flexible, translucent surface. It can be painted with any Rosco scenic paint, or carved or safely rolled without cracking or peeling. Add sand, sawdust or clay to create unique textures.

Water based



Foamcoat

An acrylic slurry the consistency of wet plaster, Foamcoat dries to a super hard durable coating for all rigid foam, resisting chipping and cracking, yet can be sanded smooth or carved with detailing. It is especially useful on scenery or props that receive excessive abuse or need to last for extended tours. Foamcoat is also a superb texturing agent that can be used to create custom patterns like bark and stone work and is even durable enough to be used on floors.

Water based

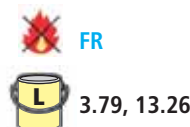

Flexcoat

Flexible, non-toxic coating for polyurethane and polystyrene foam providing excellent adhesion to a wide variety of substrates. Flexcoat contains no plasticisers, so will not become brittle with age or exterior exposure. Compatible with all Rosco paints either as tints or surface coatings.

Water based acrylic

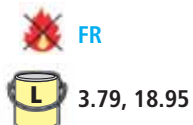

FlexBond

Clear, flexible scenic glue which bonds many porous and non-porous scenic materials. Dries to a clear, hard, yet pliable coating that does not suffer from 'tackiness' and remains extremely pliable and strong even as the materials bend and deform.

Water based



Test Kits

Kits comprise 29ml samples of each colour in the range.

- 5300 Off Broadway
- 5600 ColourCoat
- 6200 Vivid FX
- 6600 ClearColour
- 6030 Supersat
- 5700 Fluorescent



Fringes & Tassels

As well as standard bullion fringes, tassels and tie backs, hand manufactured wool fringes can also be supplied. Ranging from 210mm to 1000mm in gold, they are scaled to suit the size of the drapes. Custom colours and designs are also available.

Bullion Fringe

BFR210	Gold	210mm
BFR300	Gold	300mm
BFR500	Gold	500mm
BFR600	Gold	600mm
BFR1000	Gold	1000mm

Other fringes and tie backs are available on request.



String Curtain

A string fringe-style curtain. Ideal for separating areas in hospitality and exhibition venues.



IFR
polyester trevira



100cm



320cm approx

- STR006** White
- STR007** Black
- STR008** Red



Right: For London's Coliseum, J&C Joel made and installed this ornate tympanum. The tassels are a metre in length and weigh nearly 20kg each.

Below: Fringing tassels made for the Sunderland Empire, UK.

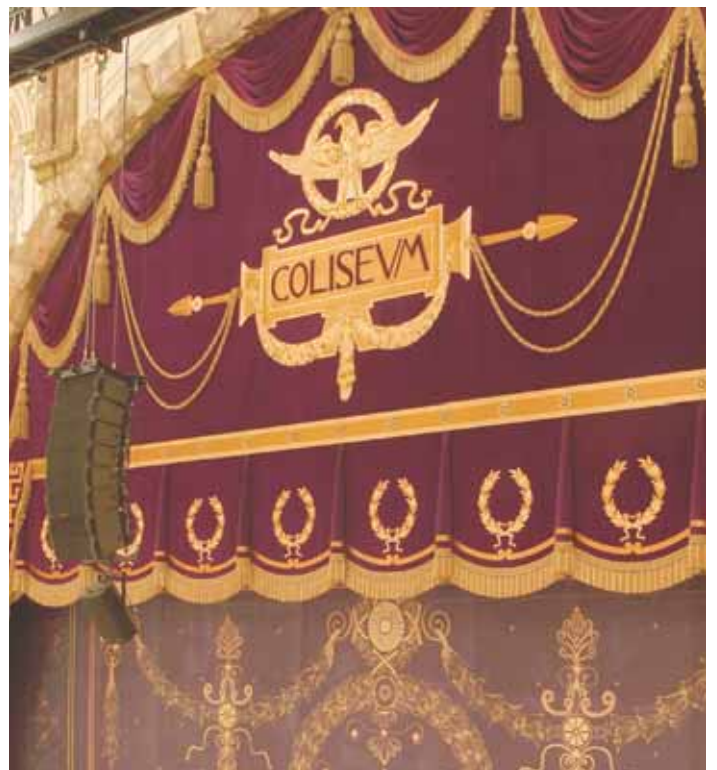

Sewing Supplies

J&C Joel is able to supply all the components required to manufacture your own drapes or just to do that mid production repair. The range includes hook and loop, both sew on or self adhesive, chain for weighting the base of curtains, eyelets, S-hooks, tab hooks, golf bag hooks and various webbing and tapes such as cotton herringbone, modacrylic and polypropylene, from 25mm to 100mm in width.

Sewing threads are available on request. We have a wide range of colours available, so please supply a colour sample for matching.



Storage Bags

A selection of canvas and PUFC standard size storage bags is available from stock. Custom bags and hampers are available on request.

Canvas Storage Bag

- SBC001 Natural 3x4ft
- SBC002 Natural 4x5ft

PUFC Storage Bag

- SBP001 Black 3x4ft
- SBP002 Black 4x5ft



Bungees

Enable screens, scrims and cloths to be tensioned onto frames and structures.

4mm x 28cm long

- BUN001 Black
- BUN002 White
- BUN003 Red



Flags

A range of sewn polyester and cotton 6' x 3' flags for national colours and sporting symbols are available from stock. Special sizes and designs, such as logos and corporate identity, are available on request.

Tapes

JCJ Serge Tape



Black wool serge on an adhesive backing. Use instead of shiny gaffer tape to invisibly repair most tears in black wool serge. Ideal for theatres, touring shows, rental companies, film and tv studios and schools, this is one of those products that will find many uses over and above the original!



↔ 50mm 🔍 25m

JST001 Black

Gaf-Fire



Fire retardant to BS5867 Pt 2 Type B. With all the features of standard gaffer tape, this is flame retardant, allowing it to be used in strictly regulated high fire risk areas.

↔ 48mm 🔍 25m

GAFB48 Black

NEC - Double Sided



Designed and manufactured specifically as an economical and easy way of fixing carpets and general floor coverings to exhibition and compound floors. It is a two-strength adhesive, the top side is a high tak adhesive giving great hold onto carpet and dance floors. The underside is a medium tak adhesive holding well onto a variety of clean and dry surfaces. Intended mainly for event and exhibition use.

↔ 50mm 🔍 50m

NEDW50 White

Black PVC Tape



A quality electrical PVC tape. Ideal for joining black dance floor. Easy to tear and unwind, plus is flame retardant to BS EN 60454 Type 2.

↔ 50mm 🔍 33m

PVCB50 Black

500 Matt MagTape



A matt version of the original gaffer tape. Offers all the same features but with a minimal 1.9% reflection ratio, making it perfect for TV and film studios. Ideal for Joelmat (see page 52).

↔ 50mm 🔍 50m

MMB50 Black
MMW50 White

Gaffer Tape – original



MagTape Original is made from a combination of polyethylene and rayon cloth to give a highly flexible and conformable tape. Very strong, easy to tear with good adhesion. Original has become a first choice with the arts and entertainment industry.

↔ 50mm 🔍 50m

GTB50 Black
GTS50 Silver
GTW50 White

Utility Gaffer



A good "economy" quality gaffer tape. Easy tear.

↔ 48mm 🔍 50m

UGB48 Black
UGS48 Silver
UGW48 White

Economy PVC Tape



An economy PVC tape that is flame retardant and has an excellent matt finish. Ideal for joining matt black dance floor.

↔ 50mm 🔍 33m

PVCBUD50 Black

ProJoin



Designed specifically for the temporary joining of stage and dance flooring. Ideal for Joelmat (see page 52).

↔ 50mm 🔍 33m

PROCL50 Clear



Joelastic Shapes

Known for its versatility when it comes to creating shapes and designs, Joelastic is used here over frames of lightweight plastic spokes to create shapes that will look good in both white light and in a colour changing environment.

Joelflakes

These white 3D snowflakes will create a winter wonderland in nightclubs, shopping centres and for any Christmas event. Available in three diameters, all 458mm deep, the snowflakes have multiple hanging points so can be hung individually or in groups. Try using a variety of sizes to create different effects.

Main picture right: *Joelflakes Sprinkle (top) and Flurry photographed at Liquid nightclub, Halifax, UK.*

Below: *Four spectacular light sculptures designed by Turner Prize nominee artist Mel Chantry and installed in Liverpool's MetQuarter. Supplied and installed by J&C Joel, the sculptures are 10m high and internally lit with LEDs.*



Flurry

SN0001 90cm / 3ft
SN0002 150cm / 5ft
SN0003 210cm / 7ft

Sprinkle

SN0007 90cm / 3ft
SN0008 150cm / 5ft
SN0009 210cm / 7ft

INDEX

	Page		Page		Page		Page
2Way Track	62	Double Fine Gauze	26	Matting & Jutes	34-35	Speaker Cloth - Wool	8
3Way Track	62	Eclipse Lining	29	Metrodeck	53	Square Gauze	28
6pt Sharkstooth	26	ERail	62	Molton & Duvetyn	30	Stage Machinery	54-56
8pt Trevira Sharkstooth	25	Euro Gauze	28	Mousseline	39	Stage Satin	42
Acoustic Banners	58	Fibre Optics & Ropes	65	Muslin	34	Staging	53
Acoustic Curtains	58	Filled Cloth	21	NEC - Double Sided Tape	70	Storage Bags	69
Acoustic Fabrics	8	Fine Gauze	26	Orion	36	Stretch Fabrics	44
Acoustic Felt	34	Flags	69	Paints & Coatings	66-67	String Curtain	68
Acoustic Transparent	8	Flooring	37, 52	Paints - Chroma Key	15	Studio Canvas, M1	18
Acoustic Velvet Velour	8	Fringes & Tassels	68	Pilewind Winches	54	Super Wool Serge	50
Barrels & Fittings	64	Gaffer Tape - Original	70	Polyester Sheeting	43	T60 Track	63
Bolton Twill	9	Gaffer Tape - Utility	70	Polyester Trevira	38	Tapes	70
Brown Flax	37	Gaf-Fire	70	Polyester Trevira Satin	42	Tapes - Chromakey	15
Brusan	10	Gauzes	25-28	Premier Blackout	29	Taylor's Sparkle	50
Bullion Fringe	68	Glacier	17	Projection Screens	40	Tiger Netting	26
Bump - Heavy Cotton	35	Hall Stage Products	63	Projoin	70	Track Systems	57-63
Bump - Synthetic	35	Heavy Bobbinet	27	PUFC Waterproof	41	Trevira Cyclorama Canvas	11
Bungees	69	Heavy Velvet Velour	48	Pulleys	56	Trevira Molton	30
Cabaret Sparkle Velvet Velour	49	Heavy Wool Serge	50	PVC Coated Fabric	41	Triple E	58-62
Canvasses	11, 18, 19	Hessian	34	PVC Stage Mat	52	Twotone	45
Casement	12-13	Hook & Loop	69	PVC Tape - Black	70	Ultra Stretch	44
Chaintrack	61	Interlinings	35	PVC Tape - Economy	70	Unibeam	60
Chromakey Cyclorama Canvas	14	Jap Silk	32-33	Reflective Gauze	28	Unitrack	60
Chromakey Products	14-15	Joelastic	44	Rope Lock	65	USA Commando Cloth	30
Chromakey Wool Serge	14	Joelastic - Chromakey	14	Ropes	65	Variable Acoustics	58-59
Coloured Wool Serge	51	Joelastic Shapes	71	Rosco	66-67	Vegas Velour	48
Cotton Calico	43	Joel Flakes	71	Sateen Lining	29	Velvets	46-49
Cotton Canvas	18	Joelmat	52	Satins	42	Velvet Velour	46
Cotton Cyclorama Canvas	11	Joel Sparkle	16	Scenery Netting	28	Velvet Velour, M1	47
Cotton Sheeting	43	Jomeleon	31	Scenic Gauze	27	Voile	39
Crushed Suede	24	Kilo Serge	50	Scrim	35	Wadding	35
Curtain Controllers	56	Laser Gauze	17	Serge Tape - JCJ	70	Walking Canvas	37
Custom Sewing	4-7	Leather Grain	23	Sewing Supplies	69	Webbing	69
Designer Fabrics	16-17	Linen Flooring	37	Sharkstooth Gauze	25	Wide Width Canvas	18
Digital Canvas	19	Linings	29	Sheeting	43	Wire Ropes	65
Digital Flat Knit	19	Liquid Lamé	16	Shimmerlite	17	Wool Serge	50-51
Dimalan	20	MagTape - 500 Matt	70	Silent Gliss	57	York Velvet	47
Display Felt	22	Maltbury	53	Speaker Cloth - Synthetic	8		

Credits:

Pictures The Sage Gateshead: *Sally Anne Norman* • London Coliseum: *Hufton & Crow/View* • Alley Arts Centre; Carriage Works; MetQuarter; St John Bosco's Art College; Scottish Television; Solstice Arts Centre; Strule Arts Centre; Sunderland Empire: *Louise Stickland* • James Wheelwright; Liquid nightclub: *Fiona Blackett*

Graphic design *The Wells Partnership* www.wellspartnership.com

Text and production *Harmer PR* www.harmerpr.com





J & C Joel Limited

jcjoel.com

Manufacturer and Installer of all types of Theatrical Drapes and Stage Equipment

Corporation Mill • Corporation Street • Sowerby Bridge • Halifax HX6 2QQ • UK

Telephone +44 (0)1422 833835 • Fax +44 (0)1422 835157 or 839642 • Email mail@jcjoel.com